



# NEW ZEALAND

## EDICT OF GOVERNMENT

In order to promote public education and public safety, equal justice for all, a better informed citizenry, the rule of law, world trade and world peace, this legal document is hereby made available on a noncommercial basis, as it is the right of all humans to know and speak the laws that govern them.

AS-NZS 1249 (2003) (English): Children's nightwear and limited daywear having reduced fire hazard [By Authority of New Zealand Product Safety Standards (Children's Nightwear and Limited Daywear Having Reduced Fire Hazard) Regulations 2008 (SR 2008/199)]

*We will sell to no man,  
we will not deny or defer to any man either justice or right.*

**Magna Carta—Tūtohingā Nui**

*Kore rawa e hoko ki te tangata, e kore e whakakāhoretia,  
e tautuku rānei te tangata ki te ture, tika ranei.*



BLANK PAGE





## Children's nightwear and limited daywear having reduced fire hazard

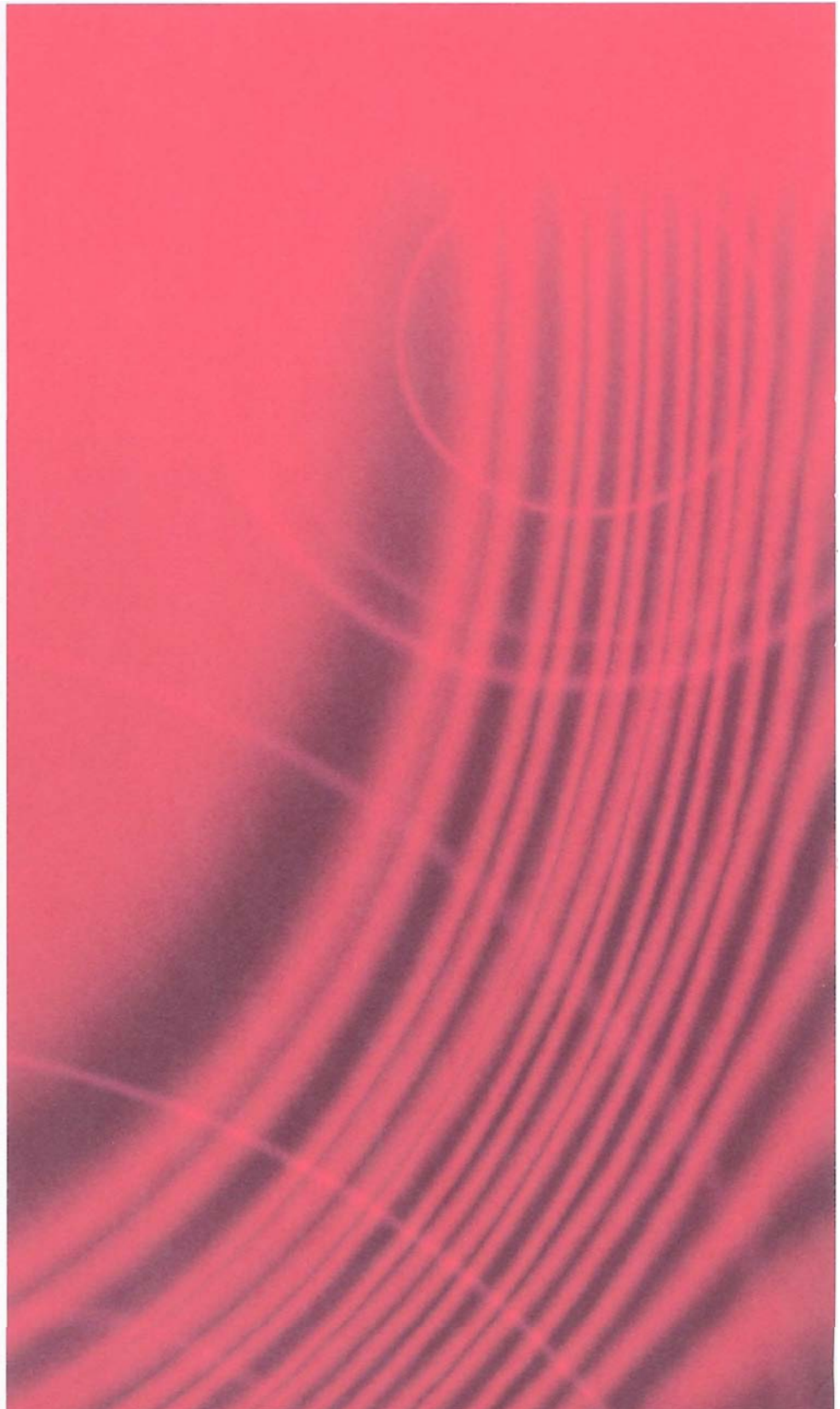

### **AS/NZS 1249:2003**

This Joint Australian/New Zealand Standard was prepared by Joint Technical Committee CS-086, Burning Behaviour of Textile Products, Floor Coverings and Furniture. It was approved on behalf of the Council of Standards Australia on 24 October 2003 and on behalf of the Council of Standards New Zealand on 12 November 2003. It was published on 29 December 2003.

New Zealand-only Amendment A is attached at the rear of this document.

---

The following are represented on Committee CS-086:

Australian Competition and Consumer Commission  
Australian Retailers Association  
Australian Wool Processors Council  
Consumers Federation of Australia  
Council of Textile and Fashion Industries of Australia  
CSIRO Building, Construction and Engineering (Australia)  
Department of Fair Trading N.S.W. Consumer Protection Agency  
Furniture Society of Victoria  
National Furnishing Industry Association of Australia  
New Zealand Furniture Manufacturers Federation  
Office of Fair Trading and Business Affairs, Vic.  
Plastics and Chemicals Industries Association (Australia)  
Retail and Wholesale Merchants Association of New Zealand  
Royal New Zealand Plunket Society  
Textile Distributors Association (Australia)  
The Treasury Competition Consumer Policy Division (Australia)  
Testing Interests  
Wool Research Organisation of New Zealand

Additional interests participating in the preparation of this Standard:

Commerce Commission, New Zealand  
Ministry of Consumer Affairs (New Zealand)  
Royal Children's Hospital, Melbourne

---

#### **Keeping Standards up-to-date**

Standards are living documents which reflect progress in science, technology and systems. To maintain their currency, all Standards are periodically reviewed, and new editions are published. Between editions, amendments may be issued. Standards may also be withdrawn. It is important that readers assure themselves they are using a current Standard, which should include any amendments which may have been published since the Standard was purchased.

Detailed information about joint Australian/New Zealand Standards can be found by visiting the Standards Australia web site at [www.standards.com.au](http://www.standards.com.au) or Standards New Zealand web site at [www.standards.co.nz](http://www.standards.co.nz) and looking up the relevant Standard in the on-line catalogue.

Alternatively, both organizations publish an annual printed Catalogue with full details of all current Standards. For more frequent listings or notification of revisions, amendments and withdrawals, Standards Australia and Standards New Zealand offer a number of update options. For information about these services, users should contact their respective national Standards organization.

We also welcome suggestions for improvement in our Standards, and especially encourage readers to notify us immediately of any apparent inaccuracies or ambiguities. Please address your comments to the Chief Executive of either Standards Australia International or Standards New Zealand at the address shown on the back cover.

---

*This Standard was issued in draft form for comment as DR 02365.*

---

# Australian/New Zealand Standard™

## **Children's nightwear and limited daywear having reduced fire hazard**

Originated in Australia as AS CL3—1969.  
Originated in New Zealand as NZS 8705:1977.  
Previous edition AS/NZS 1249:1999.  
Fifth edition 2003.  
NZ-only Amendment A published 31 May 2008.

### **COPYRIGHT**

© Standards Australia/Standards New Zealand

All rights are reserved. No part of this work may be reproduced or copied in any form or by any means, electronic or mechanical, including photocopying, without the written permission of the publisher.

Jointly published by Standards Australia International Ltd, GPO Box 5420, Sydney, NSW 2001  
and Standards New Zealand, Private Bag 2439, Wellington 6020

ISBN 0 7337 5599 2

## PREFACE

This Standard was prepared by the Joint Standards Australia/Standards New Zealand Committee CS-086, Burning Behaviour—Textile Products, Floor Coverings and Furniture, to supersede AS/NZS 1249:1999.

This Standard has undergone a number of revisions. Details of the publishing history can be obtained from the Information Centre at Standards Australia or Standards New Zealand.

In this edition, changes have been introduced to improve and clarify some parts of the Standard that were considered confusing and to provide users with a more workable document.

Changes made in this edition include:

- (a) A clearer definition of infant sleep bags.
- (b) Fabric with a pile or nap, which meets the requirements for surface burn, can be used on the 2.5 cm inside edge for all four categories.
- (c) The introduction of trim requirements for Category 3 garments.
- (d) A more specific identification of all-in-one garments that are required to comply with this Standard.
- (e) Recommendation for the labelling of garment sets where one part of the set is a Category 3 garment and the other is a garment not required to meet this Standard.
- (f) Revision of Appendix A to rectify errors and clarify the steps in the assessment process.
- (g) Removal of the reference to printed labels only, which will no longer restrict the use of woven labels.

The types of garments to which this Standard applies are listed in Clause 0.2.

In addition to the requirements of this Standard, designers must refer to national consumer regulations in Australia and New Zealand when it is intended to sell children's nightwear garments in these countries.

Garments which do not meet the requirements of any of the categories specified in Table 0.1 are considered to have a very high flammability rating, and therefore do not comply with this Standard.

Some daywear garments have been included in the Standard because of the difficulty of distinguishing between daywear and nightwear for these items. For example, Category 3 has been created to provide for some infants all-in-one style garments.

Many flame burns suffered by children involve flammable liquids. Garments complying with the requirements of this Standard will give little or no protection against burns where flammable liquids are involved.

The terms 'normative' and 'informative' have been used in this Standard to define the application of the appendix to which they apply. A 'normative' appendix is an integral part of a Standard, whereas an 'informative' appendix is only for information and guidance.

## CONTENTS

	<i>Page</i>
FOREWORD .....	5
<b>SECTION 0 SCOPE AND GENERAL</b>	
0.1 SCOPE.....	6
0.2 APPLICATION .....	6
0.3 OBJECTIVE .....	7
0.4 REFERENCED DOCUMENTS.....	7
0.5 DEFINITIONS.....	7
0.6 CLASSIFICATION .....	10
0.7 GENERAL REQUIREMENT.....	10
<b>SECTION 1 CATEGORY 1 GARMENTS</b>	
1.1 SCOPE OF SECTION .....	11
1.2 BURNING BEHAVIOUR REQUIREMENTS FOR FABRICS.....	11
1.3 TRIMS.....	12
1.4 ATTACHMENTS AT THE NECK OPENING OF A GARMENT (EXCLUDING BASQUES).....	12
1.5 FIRE HAZARD INFORMATION LABEL.....	13
<b>SECTION 2 CATEGORY 2 GARMENTS</b>	
2.1 SCOPE OF SECTION .....	14
2.2 GENERAL.....	14
2.3 SURFACE BURNING TIME FOR FABRICS WITH A PILE OR NAP .....	14
2.4 DIMENSIONAL REQUIREMENTS.....	14
2.5 TRIMS.....	15
2.6 ATTACHMENTS AT THE NECK OPENING OF A GARMENT (EXCLUDING BASQUES).....	15
2.7 FASTENINGS .....	15
2.8 SLITS .....	15
2.9 FIRE HAZARD INFORMATION LABEL.....	15
<b>SECTION 3 CATEGORY 3 GARMENTS</b>	
3.1 SCOPE OF SECTION .....	21
3.2 SURFACE BURNING TIME FOR FABRICS WITH A PILE OR NAP .....	21
3.3 TRIMS.....	21
3.4 FIRE HAZARD INFORMATION LABEL.....	21
<b>SECTION 4 CATEGORY 4 GARMENTS</b>	
4.1 SCOPE OF SECTION .....	22
4.2 SURFACE BURNING TIME FOR FABRICS WITH A PILE OR NAP .....	22
4.3 USE OF FABRICS WITH A CELLULOSIC, ACETATE OR ACRYLIC FIBRE CONTENT.....	22
4.4 QUILTED FABRICS.....	23
4.5 INFANT SLEEPBAGS.....	23
4.6 FIRE HAZARD INFORMATION LABEL.....	23

## SECTION 5 MARKING

5.1	SCOPE OF SECTION .....	25
5.2	INFORMATION TO BE SUPPLIED .....	25
5.3	LOCATION OF LABEL INCORPORATING THE FIRE HAZARD INFORMATION.....	25
5.4	DURABILITY OF LABEL INCORPORATING THE FIRE HAZARD INFORMATION.....	25
5.5	FIRE HAZARD INFORMATION AND SYMBOL.....	26
5.6	PAPER PATTERNS.....	26

## APPENDICES

A	GUIDE TO THE PROCEDURE FOR DETERMINING THE CATEGORIES FOR CHILDREN'S NIGHTWEAR AND LIMITED DAYWEAR.....	28
B	GENERAL INDICATION OF THE BURNING BEHAVIOUR OF DIFFERENT CLASSES OF FIBRES .....	29
C	INDICATIONS OF NIGHTWEAR FOR CHILDREN'S GARMENTS .....	31
D	WASH PROCEDURE .....	33
E	TABLES RELATED TO TRIMS REQUIREMENTS.....	34
F	METHOD OF TEST FOR CATEGORY 1 AND CATEGORY 2 GARMENTS WHICH HAVE A TOTAL AREA OF APPLIQUES, MOTIFS AND OVERLAYS GREATER THAN THAT PERMITTED IN APPENDIX E, TABLE E1 .....	36
G	SOME EXAMPLES OF CALCULATING ALLOWABLE AMOUNT OF TRIMS—CATEGORY 1 GARMENTS.....	37
H	SOME EXAMPLES OF TRIMS WHICH EXCEED ALLOWABLE AMOUNT AND WHICH THEREFORE ARE <u>NOT</u> ACCEPTABLE— CATEGORY 1 GARMENTS .....	38
I	EXAMPLES OF STYLES OF GARMENTS WHICH COMPLY WITH THE DESIGN REQUIREMENTS FOR CATEGORY 2 GARMENTS.....	39
J	METHOD FOR DETERMINING DURABILITY AND ATTACHMENT OF LABEL INCORPORATING FIRE HAZARD INFORMATION .....	41



## FOREWORD

The following explanatory notes give some of the reasons for the principles and requirements set out in this Standard. They are based on information collected as a result of burning accidents and on extensive laboratory investigations:

(a) *Fabrics with pile or nap surface*

Fabrics which have a pile or nap, e.g. fluffy types of fabrics, are far more prone to surface burning than fabrics which have no loose fibres on the surface. Although it would be difficult to exclude all these types of flammable fabrics from traditional nightwear, the performance requirements in this Standard reduce the risk of surface burn.

(b) *Garment style*

Loose flowing styles of garments, whether in the form of nightdresses, dressing gowns, pyjamas with bell-bottom trousers or loose sleeves, sloppy jackets, or shirts, are likely to come in contact with inadequately guarded home-heating appliances. Some trims attached to garments especially along the edges are more readily ignited than the bulk of the fabric. This Standard is designed to reduce these hazards.

(c) *Fabrics made from fibres that melt*

If fabrics which melt come in contact with a flame, they may shrink away before they ignite. If they do ignite, melted drops fall off and may take the burning portion away from the body of the fabric. Their greatest danger lies in the possibility of the molten material coming in contact with the body.

(d) *Heating appliances*

Many older types of heating appliances, which do not have adequate guards, remain in use for long periods. These may be electrical appliances, or kerosene or gas heaters. Open fires are sometimes left unguarded with children playing nearby. Garments are also known to ignite when a loose sleeve comes in contact with a lighted gas burner or an electric hotplate on a stove.

## STANDARDS AUSTRALIAN/STANDARDS NEW ZEALAND

**Australian/New Zealand Standard****Children's nightwear and limited daywear having reduced fire hazard**

## SECTION 0 SCOPE AND GENERAL

**0.1 SCOPE**

This Standard specifies design, performance and labelling requirements for four categories of children's nightwear, together with some garments commonly worn both day and night. It also covers requirements for the labelling of paper patterns for these garments.

## NOTES:

- 1 Appendix A is a flow chart which will be of assistance in interpreting the Standard when designing children's nightwear.
- 2 Appendix B provides a general indication of the burning characteristics of different types of fibres; however, it is not possible to accurately predict the burning behaviour of any garment solely on the basis of the fibre content of the component fabric or fabrics. Prediction of the burning behaviour of garments incorporating fibre blend is not possible from data on the individual fibres in the blend (see warning in Appendix B).
- 3 There are some garments which will not meet the requirements of any of the categories in this Standard and therefore cannot comply with this Standard.

**0.2 APPLICATION**

This Standard applies to nightwear garments in sizes ranging from 00 to 14, the number scheme used in AS 1182.

## Included are—

- (a) knitted all-in-ones in Sizes 00 to 2 where the close-fitting portion of the garment occupies 80% or more of the total surface area of the garment;  
NOTE: There are a number of daywear all-in-one garments that are designed with other garments attached, for example a dress attached to a romper. It is not the Committee's intention that these garments be subjected to the Standard.
- (b) recognized, exclusively styled nightwear garments;
- (c) woven all-in-ones in Sizes 00 to 2 and all-in-ones above Size 2 if they are of a style which identifies them as nightwear;
- (d) boxer shorts of a loose style commonly used as nightwear; and
- (e) infant sleep bags with sleeves or arm openings.

## Excluded are—

- (i) predominantly knitted all-in-ones in Sizes 00 to 2 made from fabric with a mass equal to or greater than 280 g/m<sup>2</sup> and clearly daywear;
- (ii) predominantly knitted all-in-ones with a fabric of mass less than 280 g/m<sup>2</sup> in sizes 00 to 2; and where the surface area of the close fitting portion of the garment is less than 80% of the total surface area of the garment and which are clearly not nightwear;
- (iii) woven all-in-ones in Sizes 00 to 2 and all-in-ones above Size 2 which are not of a style which identifies them as nightwear;
- (iv) boxer shorts in form fitting styles, commonly worn as underwear;

- (v) tee-shirts;
- (vi) sheets and blankets that incorporate a partial garment.
- (vii) infant sleepbags without sleeves or arm openings.

NOTE: Attention is drawn to Appendix C which gives some indicators which will assist in identifying garments which are styled to be worn as nightwear.

### 0.3 OBJECTIVE

The objective of this Standard is to provide criteria to assess the fire hazard of children's nightwear for the purpose of classification and for labelling of garments according to their fire hazard.

### 0.4 REFERENCED DOCUMENTS

The following documents are referred to in this Standard:

#### AS

- |           |  |
|-----------|--|
| 1182      | Size coding scheme for infants' and children's clothing—Underwear and outerwear  |
| 2001      | Methods of test for textiles   |
| 2001.2.13 | Method 2.13: Physical tests—Determination of mass per unit area and mass per unit length of fabrics  |
| 2001.4.15 | Method 4.15: Colourfastness tests—Determination of colourfastness to washing   |
| 2001.5.4  | Method 5.4: Dimensional change—Determination of dimensional change in laundering of textile fabrics and garments —Automatic machine method |
| 2700      | Colour Standards for general purposes  |

#### NZS

- |      |   |
|------|---|
| 7702 | Specification for colours for identification, coding and special purposes |
|------|---|

#### ISO

- |         |   |
|---------|---|
| 105     | Textiles —Tests for colourfastness  |
| 105-A02 | Part A02: Grey scale for assessing change in colour   |
| 6941    | Textile fabrics—Burning behaviour—Measurement of flame spread properties of vertically oriented specimens |
| 10047   | Textiles—Determination of surface burning time of fabrics   |

### 0.5 DEFINITIONS

For the purpose of this Standard, the definitions below apply.

#### 0.5.1 Acetate fibre

Secondary cellulose acetate or cellulose triacetate.

NOTE: Secondary cellulose acetate has less than 92 percent but at least 74 percent of the hydroxyl group acetylated. Cellulose triacetate has at least 92 percent of the hydroxyl groups acetylated.

#### 0.5.2 Acrylic fibre

Fibre formed of linear macromolecules comprising at least 85 percent (by mass) of the acrylonitrilic pattern in the chain.

### 0.5.3 All-in-ones

Single piece garments designed to be joined at the crotch or permanently joined at the crotch, which cover the torso from at least the crotch to the chest and which may include sleeves and legs. Examples of these garments are jumpsuits, coveralls, romper suits, stretch and grows, gro-suits and overalls. Swimwear is excluded.

NOTES:

- 1 Predominantly knitted all-in-ones in Sizes 00 to 2 made from fabrics of mass less than  $280 \text{ g/m}^2$  are covered under Category 3 only if the close fitting portion of the garment occupies 80% or more of the total surface area of the garment.
- 2 Predominantly woven all-in-ones in Sizes 00 to 2 and all-in-ones above Size 2 are covered under Categories 1, 2 and 4, if classed as nightwear.
- 3 Predominantly knitted all-in-ones in Sizes 00 to 2 where the close fitting portion of the garment occupies less than 80% of the total surface area of the garment and are clearly nightwear are subject to the requirements of Categories 1, 2 and 4.

### 0.5.4 Basque

A continuous band of knitted ribbing elasticized fabric or elastic on the neck, waist or cuff hems of garments, designed to fit the body.

### 0.5.5 Cellulosic fibre

Either—

- (a) a natural cellulosic fibre (e.g. cotton, linen); or
- (b) a regenerated cellulosic fibre (e.g. cupro, viscose or modal or other process including deacetylation).

### 0.5.6 Fabric

A woven, knitted or non-woven textile material in the form of single or multicomponent (coated, quilted and multilayered sandwich construction and similar combinations) materials.

NOTE: A lining is considered a separate fabric.

### 0.5.7 Flame spread time

The time taken by a flame on a burning material to travel from the first to the third marker threads when tested in accordance with ISO 6941, using a 10 s surface ignition time.

### 0.5.8 Free edge

The width of a trim being the measured distance from the attaching stitching to the outermost edge of the trim.

NOTE: Where double row or zigzag stitching is used to attach the trim, the measurement is taken to the line of stitching nearest to the edge (see Figure 0.1(a), (b) and (c)).

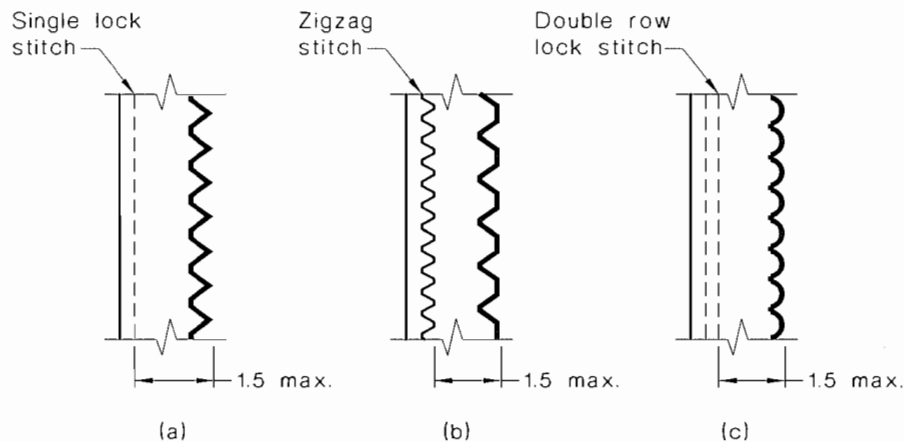

DIMENSIONS IN CENTIMETRES

FIGURE 0.1 FREE EDGE ON TRIMMING

#### 0.5.9 Insert

A decorative or contrasting piece of fabric, inserted between edges of the main fabric of the garment.

#### 0.5.10 Nightwear

Garments of a type suitable for night wear, such as pyjamas, pyjama-style overgarments, nightdresses, nightshirts, dressing gowns, bathrobes and infant sleepbags, and garments such as all-in-ones and boxer shorts which may be suitable for daywear or nightwear. (See Note 1 to Clause 0.1).

Does not include any articles of headwear, leggings either with or without a foot, footwear or handwear.

#### 0.5.11 Predominantly

50% or more of the total area of the garment.

#### 0.5.12 Surface burning time

The time required for the pile or nap of a fabric to burn to the reference mark when tested in accordance with ISO 10047. It is expressed as the minimum value of a number of determinations made during testing of the fabric.

#### 0.5.13 Trims

Trimming such as piping, patch-pockets, ribbon, overlays, lace, frills, inserts, motifs, appliques, edge trim other than basques, and similar ornaments, but not the following:

- (a) Basques.
- (b) Attachments at the neck opening of a garment.

NOTE: Attachments at the neck opening of a garment are not defined as trims but are covered separately in each Section, as applicable.

- (c) Belt loops.
- (d) Belts and cords at the waist with or without tassels.

NOTE: Belts and cords at the waist provide increased safety for the wearer by minimizing the 'chimney effect' of hot gasses and flame rising between the garment and the wearer in case of a fire.

- (e) Elastic.

- (f) Elasticized fabric.
- (g) Embroidery.
- (h) Ribbed fabric used in neck, waist or cuff hems.
- (i) Fabric-covered buttons.
- (j) Soling material used in garments with integral shoe pads.
- (k) Detachable bibs.
- (l) Hanger loops.
- (m) Appliques, motifs, pockets, overlays, frills and inserts made from the same fabric, but not necessarily the same colour as the base fabric of the garment.

## 0.6 CLASSIFICATION

For the purpose of this Standard, the categories of children's nightwear shall be set out in Table 0.1.

## 0.7 GENERAL REQUIREMENT

If the nightwear garment consists of more than one piece, the pieces shall be assessed independently, but each piece shall be labelled according to the requirements of the highest risk category of any one piece.

**TABLE 0.1**  
**CATEGORIES OF CHILDREN'S NIGHTWEAR**

Category	Description	Fire hazard information label
1	Garments made from fabric of the low fire hazard type and which comply with Section 1	LOW FIRE DANGER
2	Garments made from fabric which does not comply with Section 1 but which are designed to reduce fire hazard and which comply with Section 2	
3	All-in-one garments made predominantly from knitted fabrics, in Sizes 00 to 2, which comply with Section 3	
4	Garments which do not comply with Sections 1 to 3, but which comply with Section 4	<p><b>WARNING</b> HIGH FIRE DANGER KEEP AWAY FROM FIRE</p> 

NOTE: See Section 5 and Table 5.1 for labelling requirements.

## SECTION 1 CATEGORY 1 GARMENTS

### 1.1 SCOPE OF SECTION

This Section covers requirements for garments made from fabric of the low fire hazard type. These are—

- (a) burning behaviour requirements for the fabric or fabrics (see Clause 1.2);
- (b) requirements for trims (see Clause 1.3);
- (c) requirements for attachments at the neck opening of the garment (see Clause 1.4); and
- (d) the label to appear on the garment (see Clause 1.5).

### 1.2 BURNING BEHAVIOUR REQUIREMENTS FOR FABRICS

Fabrics for children's nightwear that are classified as Category 1 shall have the following burning behaviour:

(a) *Flame spread time*

When tested in accordance with ISO 6941 the flame spread time shall be 12 s or greater in the lengthwise direction and the widthwise direction, and no one determination of the time to burn a test specimen shall be less than 10 s in either the lengthwise direction or the widthwise direction. These requirements shall be met before and after washing in accordance with Appendix D.

Where there is insufficient length of sample to cut test specimens in one piece, not more than two pieces per specimen, cut in the same direction, may be butt-jointed but not overlapped. The butt-joint shall be secured with five light weight staples spaced evenly across the test specimen. The joint shall not be below the centre of the specimen when attached to the vertical test frame specified in ISO 6941.

If, after a repeat test, as required by the relevant clause of ISO 6941, four or more of six specimens fail to burn to the third marker thread in the lengthwise direction, and four or more of six specimens fail to burn to the third marker thread in the widthwise direction, the material shall be deemed to have passed the flame spread time test.

NOTE: ISO 6941 states that, if in any one set of three specimens, one result exceeds the lowest result by 50 percent for no apparent reason, or, if one or two specimens fail to reach one of the marker threads, another set of three specimens are required to be tested for that direction or face.

(b) *Surface burning time of fabrics with a pile or nap*

The following shall apply:

- (i) When tested in accordance with ISO 10047, fabrics, including basques, with a pile or nap shall have a surface burning time of 10 s or greater after washing in accordance with Appendix D.
- (ii) If a garment contains a fabric with a pile or nap on the inside which does not comply with the surface burning time requirements, there shall be either—
  - (a) a fabric without a pile or nap; or
  - (b) a fabric with a pile or nap which meets the surface burn requirements, which extends for at least 2.5 cm on the inside of the garment including sleeves of any length, and all openings below the waistline, including leg openings.

(c) *Combination of fabric and trim*

Where required throughout the Standard, the combination of fabric and trim shall be tested by cutting the specimens so that the point of application of the flame (20 mm from the bottom of the specimen) is at the bottom edge of the trim. The test shall be in accordance with ISO 6941, using a 10 s ignition time.

### 1.3 TRIMS

If the combination of fabric and trim conforms to the flame spread and surface burning time limits specified in Clause 1.2, no limitations apply to the use of trims. Other trims shall meet the following requirements:

- (a) Edge trims on any edge of the garment other than the neck opening shall not have a free edge wider than 1.5 cm (see Figure 0.1).
- (b) Trims other than edge trims with a free edge, shall have a sum total width of free edge of not more than 5 cm (see Figure 0.1).
- (c) Trims shall not have loose portions or attachments wider than 1.5 cm, or extend more than 10 cm from their point of attachment to the garment, or beyond the hem or cuffs of the garment.
- (d) Appliques, motifs and overlays shall be limited to the total amount of area in Appendix E, Table E1 for the range of garment sizes listed, and may be anywhere on the garment.
- (e) Garments with a total area of appliques, motifs and overlays which exceeds the area specified in Appendix E, Table E1, shall be tested in accordance with Appendix F. The flame spread time for the fabric including trim, shall be not less than the fabric without trim.
- (f) Inserts may be used above the waistline or above the elbow on the sleeve (see Appendix E, Table E2) without restriction.
- (g) Inserts used below the waistline or below the elbow on the sleeve shall be limited to the amount of area in Table E1 for the range of garment sizes listed.
- (h) There may be corded trim or piping in any material in any orientation provided it does not have free ends.

NOTES:

- 1 Attention is drawn to Clause 0.5.13 which defines trims and lists exclusions. Basques, which are defined in Clause 0.5.4 are excluded from trim requirements. Attachments at the neck opening of a garment are covered in Clause 1.4.
- 2 Some examples of calculating the allowable amount of trims for Category 1 garments are given in Appendix G and some examples of trims which exceed the allowable amount and are therefore unacceptable are given in Appendix H.

### 1.4 ATTACHMENTS AT THE NECK OPENING OF A GARMENT (EXCLUDING BASQUES)

If the combination of garment fabric and attachments at the neck opening of the garment conform to the flame spread and surface burning time limits specified in Clause 1.2, no limitations are applied to their use.



Either the width or the length (as applicable) of any other attachment at the neck opening of the garment when measured from the neck seam shall not be more than the distance given in the following table:

<b>Sizes 00 to 9</b>	<b>Sizes 10 to 14</b>
<b>cm</b>	<b>cm</b>
10	15

### **1.5 FIRE HAZARD INFORMATION LABEL**

The label to appear on garments which comply with this Section shall be in accordance with Section 5 and shall be as shown in Table 5.1.

## SECTION 2 CATEGORY 2 GARMENTS

### 2.1 SCOPE OF SECTION

This Section covers requirements for garments made from more flammable fabric than those which comply with Section 1. Garments complying with this Section are styled to reduce fire hazard. The requirements of this Section are—

- (a) burning behaviour requirements for fabrics with a pile or nap (see Clause 2.3);
- (b) dimensional requirements for the garment (see Clause 2.4);
- (c) requirements for trims (see Clause 2.5);
- (d) requirements for attachments at the neck opening of the garment (see Clause 2.6);
- (e) requirements for fastenings (see Clause 2.7); and
- (f) requirements for slits (see Clause 2.8)
- (g) the label to appear on the garment (see Clause 2.9).

NOTE: The garments covered in this Section include pyjamas, pyjama-style overgarments and sleep suits i.e. closer fitting garments, that because of their style are less likely to come into contact with an ignition source. Some examples of styles of Category 2 garments are illustrated in Appendix I.

### 2.2 GENERAL

Garments which meet the requirements of Clauses 2.3 and 2.4 but do not meet Clauses 2.5, 2.6, 2.7 or 2.8 shall be designated Category 4 and shall be labelled according to that category.

### 2.3 SURFACE BURNING TIME FOR FABRICS WITH A PILE OR NAP

The following shall apply:

- (a) When tested in accordance with ISO 10047, fabrics, including basques, with a pile or nap shall have a surface burning time of 10 s or greater after washing in accordance with Appendix D.
- (b) If a garment contains a fabric with a pile or nap on the inside which does not comply with the surface burning time requirements, there shall be either—
  - (i) a fabric without a pile or nap; or
  - (ii) a fabric with a pile or nap which meets the surface burn requirements, which extends for at least 2.5 cm on the inside of the garment including sleeves of any length, and all openings below the waistline, including leg openings.

### 2.4 DIMENSIONAL REQUIREMENTS

The dimensions of the garment shall conform to the limits set out in Table 2.1, and the following shall also apply:

- (a) One-piece garments which do not have a jacket do not have to be measured for a width measurement.
- (b) The width given for the sleeve and pants-leg shall be the maximum width for the entire sleeve or pants-leg below the point of measurement.
- (c) The pants-leg width at the ankle shall not be greater than that at the knee.

- (d) For sleeves and pants legs which are drawn in by elastic or by a basque, the measurement shall be taken with the garment in its finished state, i.e. with elastic in its relaxed state.
- (e) Where the garment has shoulder straps consisting of loose end ties, the length of the garment plus the length of the loose tie, shall not exceed the allowable top length stated in Table 2.1 by more than 25 cm.
- (f) Where garments are marked with a range of sizes e.g. 4–6, the garments shall meet the dimensional requirements of the smaller size.

## **2.5 TRIMS**

If the combination of fabric and trim conforms to the flame spread and surface burning time limits specified in Clause 1.2, no limitations are applied to the use of trims. Other trims shall meet the following requirements:

- (a) Except for patch-pockets that have no edge trim on the pocket opening, trims shall not have a free edge wider than 1.5 cm (see Figure 0.1).
- (b) Trims shall meet the requirements of Clause 1.3, Items (c) to (h). Garments with a total area of appliques, motifs and overlays which exceeds the area specified in Appendix E, Table E1, shall be tested in accordance with Appendix F. The flame spread time for the fabric including trim, shall be not less than the fabric without trim.

## **2.6 ATTACHMENTS AT THE NECK OPENING OF A GARMENT (EXCLUDING BASQUES)**

Attachments at the neck opening of a garment, excluding basques, shall be in accordance with Clause 1.4.

## **2.7 FASTENINGS**

Garments fastened down the length of the top shall have a secure closure within 15 cm of the lower hem.

## **2.8 SLITS**

Slits shall extend no more than 15 cm from the lower hem.

## **2.9 FIRE HAZARD INFORMATION LABEL**

The label to appear on garments which comply with this Section shall be in accordance with Section 5 and shall be as shown in Table 5.1.

**TABLE 2.1**  
**MAXIMUM DIMENSIONS FOR GARMENTS IN CATEGORY 2**

Size	Top-length*	Top-width at hem† (½ circumference)	Top-sleeve width‡ (½ circumference)	Pants-leg width§ (½ circumference)
	<i>A</i> cm	<i>B</i> cm	<i>C</i> cm	<i>D</i> cm
00	34	35	14	21.5
0	37	36	14	21.5
1	40	38	15	22
2	43	40	15.5	23
3	46	41	16	23.5
4	48	42	16	24.5
5	50	46	16.5	25
6	53	48	17	26
7	54	49	17.5	27
8	56	52	18	28
9	58	53	18.5	29
10	60	54	19	30
11	62	56	19.5	31
12	64	58	20	32
14	68	62	21	34

\* Top-length A is the length of the top as measured from the shoulder/neck point to the lower edge of the top (see Figure 2.1).

† Top-width B is the width of the top at the hem when fastened, laid flat and relaxed (see Figure 2.2).

‡ Top-sleeve width C is the width of the sleeve when laid flat, measured at a point at right angles to the top edge, 3 cm from the junction of sleeve and body, or where there is no distinct armhole seam, 3 cm from a line tangent to the curved armpit region.

Where the sleeve length at underarm is less than 3 cm, the measurement is taken at the sleeve opening (see also Figure 2.3).

§ Pants-leg width D is the width of the leg when laid flat, measured as shown in Figure 2.4.

Where leg length is less than 3 cm, the measurement is taken at the leg opening (see also Figure 2.4).

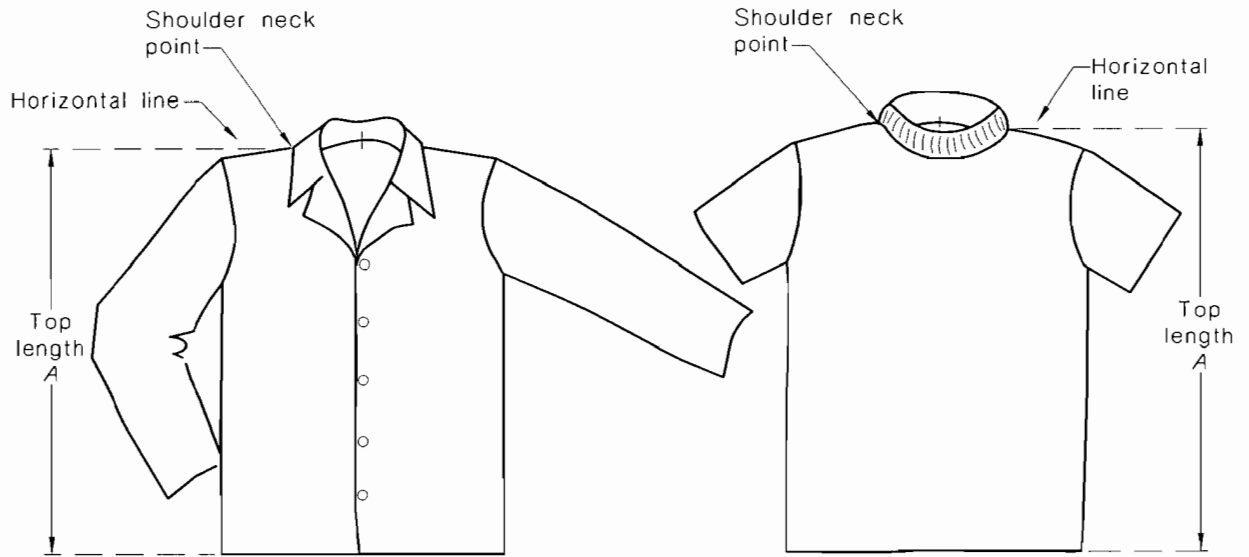

Example (a)

Example (b)

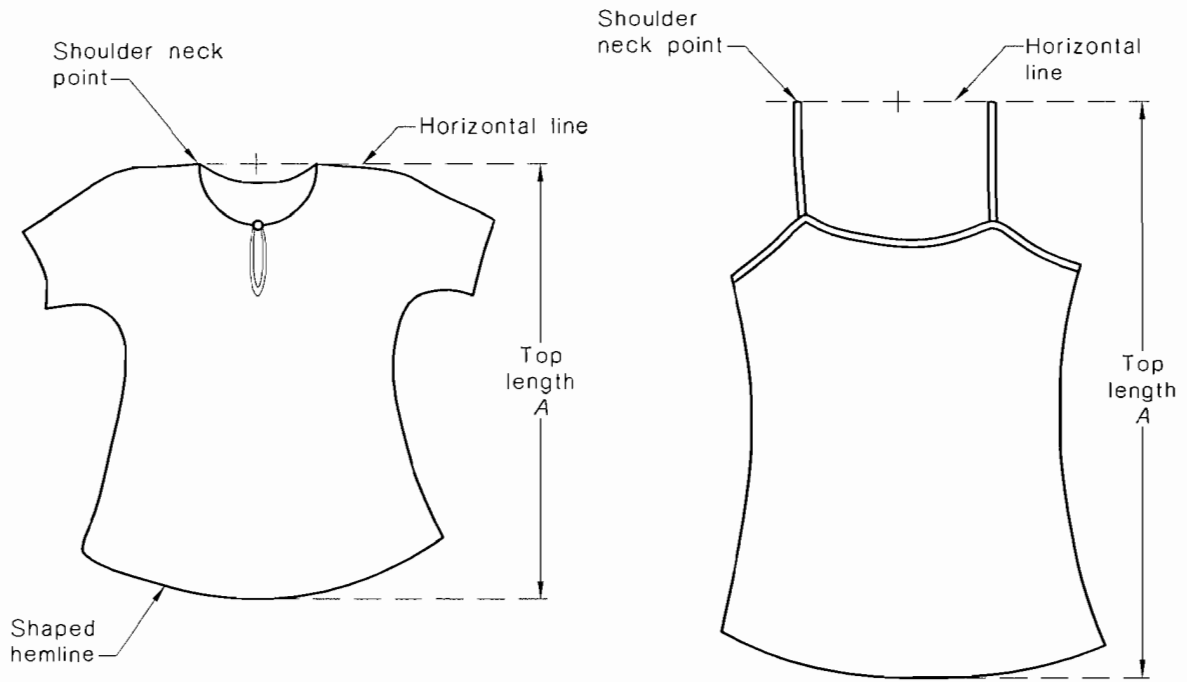

Example (c)

Example (d)

FIGURE 2.1 LOCATION OF MEASUREMENT POINTS FOR TOP LENGTH A

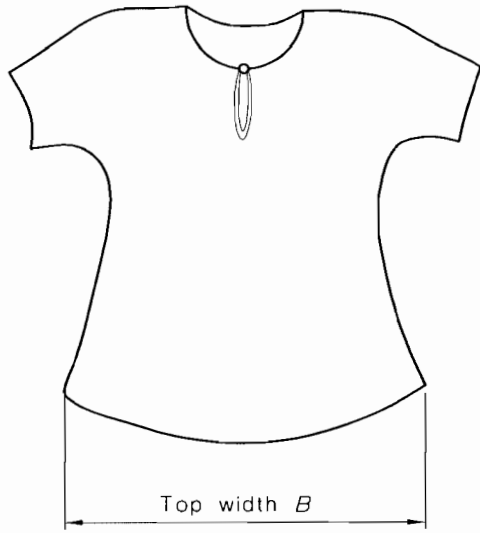

(a) Shaped hemline

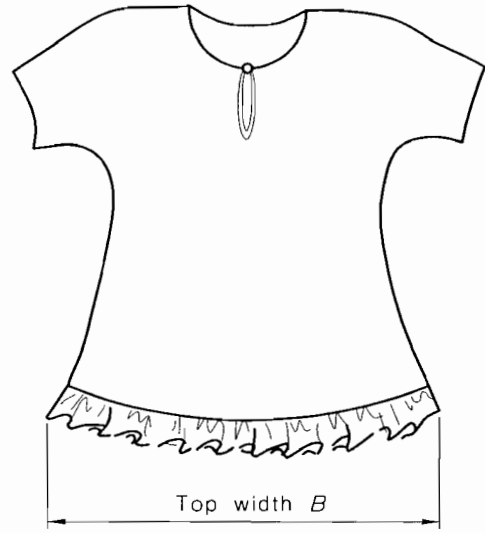

(b) Shaped hemline with frill

FIGURE 2.2 LOCATION OF MEASUREMENT POINTS FOR TOP WIDTH B

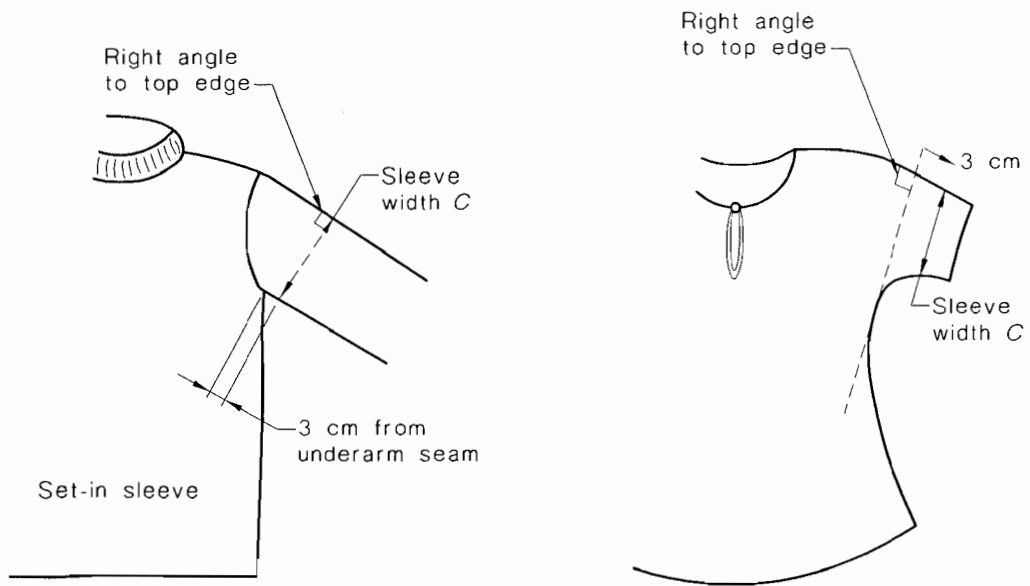

(a) Sleeve where there is an armhole seam

(b) Sleeve where there is no distinct armhole seam

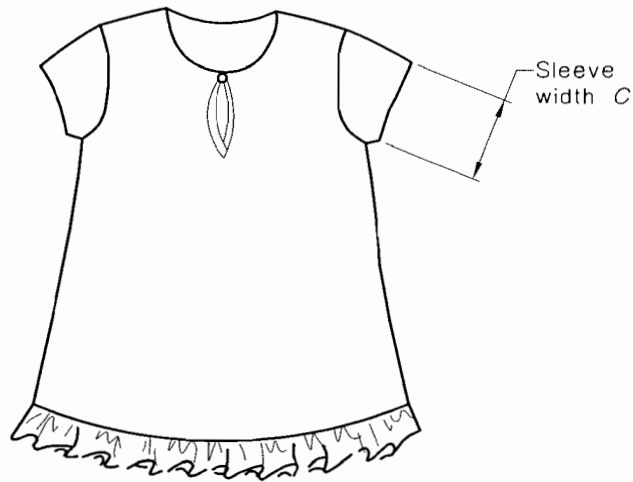

(c) Sleeve with no measurement point (i.e. underarm is less than 3 cm)

FIGURE 2.3 LOCATION OF MEASUREMENT POINTS FOR SLEEVE WIDTH  $C$

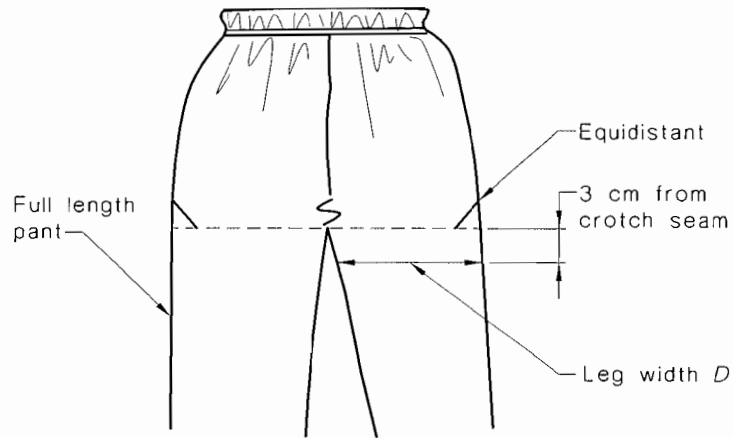

(a) Pant with leg length measuring 3 cm or more from the crotch

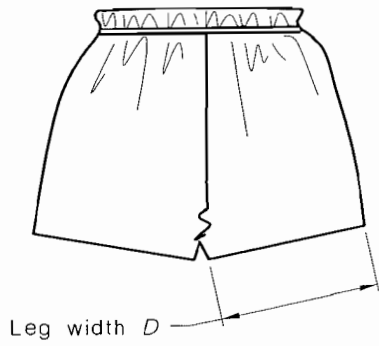

(b) Pant with no measurement point, (i.e. in-leg length is less than 3 cm)

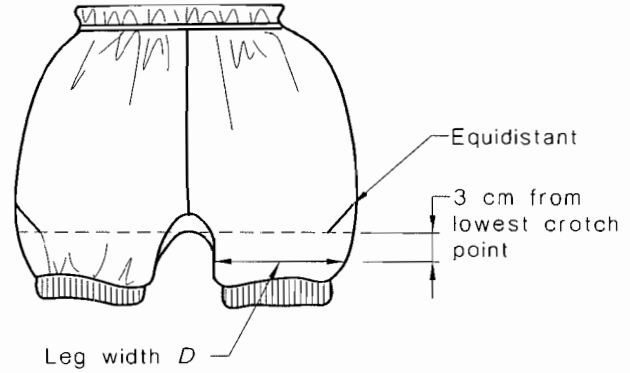

(c) Pant with a gusset, (i.e. there is no obvious crotch seam)

FIGURE 2.4 LOCATION OF MEASUREMENTS POINTS FOR LEG WIDTH  $D$



## SECTION 3 CATEGORY 3 GARMENTS

### 3.1 SCOPE OF SECTION

This Section covers requirements for all-in-one style garments—

- (a) made predominantly from knitted fabrics with a mass less than 280 g/m<sup>2</sup> when determined in accordance with AS 2001.2.13, in Sizes 00 to 2; and
- (b) where the surface area of the close fitting portion of the garment is more than 80% of the total surface area of the garment.

The requirements are—

- (i) burning behaviour requirements for the fabric or fabrics (see Clause 3.2);
- (ii) requirements for trims (see Clause 3.3); and
- (iii) the label to appear on these garments (see Clause 3.4).

#### NOTES:

- 1 All other all-in-ones made which are of a style which identifies them as nightwear (see Appendix A) are subject to the requirements of Categories 1, 2 or 4.
- 2 If a Category 3 garment forms part of a set with a garment that is not nightwear, information should be provided stating that:

‘Only the all-in-one garment has been assessed for fire hazard’.

This should be conveyed by some kind of visible statement attached to the Category 3 garment for example, by sewn in label, adhesive label, swing tag or printed on packaging. This does not apply where all parts in the set have been assessed and labelled according to this Standard.

### 3.2 SURFACE BURNING TIME FOR FABRICS WITH A PILE OR NAP

The following shall apply:

- (a) When tested in accordance with ISO 10047, fabrics, including basques, with a pile or nap shall have a surface burning time of 10 s or greater after washing in accordance with Appendix D.
- (b) If a garment contains a fabric with a pile or nap on the inside which does not comply with the surface burning time requirements, there shall be either—
  - (i) a fabric without pile or nap; or
  - (ii) a fabric with pile or nap which meets the surface burn requirements, which extends for at least 2.5 cm on the inside of the garment including sleeves of any length, and all openings below the waistline, including leg openings.

### 3.3 TRIMS

If the garments contain a trim with a pile or nap, the trim shall not exceed the area requirements specified in Table E1 or shall pass the surface burn requirements as specified in Clause 3.2(a).

### 3.4 FIRE HAZARD INFORMATION LABEL

The label to appear on garments which comply with this Section shall be in accordance with Section 5 and shall be as shown in Table 5.1.

## SECTION 4 CATEGORY 4 GARMENTS

### 4.1 SCOPE OF SECTION

This Section covers requirements for garments which do not comply with Sections 1 to 3. These requirements are—

- (a) burning behaviour requirements for fabrics with a pile or nap (see Clause 4.2);
- (b) use of fabrics with a cellulosic, acetate or acrylic fibre content (see Clause 4.3);
- (c) use of quilted fabrics (see Clause 4.4);
- (d) requirements for infant sleepbags (see Clause 4.5); and
- (e) the label to appear on these garments (see Clause 4.6).

NOTE: These fabrics are required to meet criteria on mass and fabric content because of their higher flammability characteristics.

Garments that have no pile or nap, do not have cellulosic, acetate or acrylic content greater than 50 percent, are not quilted and are not sleepbags are not subject to any restrictions under this Section, i.e. they comply with the Standard and are required to be labelled in accordance with Clause 4.6.

There are some garments which will not meet the requirements of any of the categories in this Standard and therefore cannot comply with this Standard.

### 4.2 SURFACE BURNING TIME FOR FABRICS WITH A PILE OR NAP

The following shall apply:

- (a) When tested in accordance with ISO 10047 fabrics, including basques, with a pile or nap shall have a surface burning time of 10 s or greater after washing in accordance with Appendix D.
- (b) If a garment contains a fabric with a pile or nap on the inside which does not comply with the surface burning time requirements, there shall be either—
  - (i) a fabric without a pile or nap; or
  - (ii) a fabric with a pile or nap which meets the surface burn requirements, which extends for at least 2.5 cm on the inside of the garment including sleeves of any length, and all openings below the waistline, including leg openings.

### 4.3 USE OF FABRICS WITH A CELLULOSIC, ACETATE OR ACRYLIC FIBRE CONTENT

Base fabrics which do not satisfy the requirements of Section 1, and have a cellulosic, acetate or acrylic fibre content or their mixtures of 50 percent or more shall—

- (a) have a mass of less than 130 g/m<sup>2</sup> when tested in accordance with AS 2001.2.13; and
- (b) in any garments in which this fabric is used, have a length conforming to the limits in Table 4.1. (See example in Figure 4.1).
- (c) where the garment has shoulder straps consisting of loose end ties, the length of the garment plus the length of the loose tie shall not exceed the allowable length stated in Table 4.1 by more than 25 cm.
- (d) where garments are marked with a range of sizes, e.g. 4–6, the garment shall meet the dimensional requirements of the smaller size.

#### 4.4 QUILTED FABRICS

Quilted fabrics which do not comply with Clause 1.2 shall have a total content of cellulosic, acetate or acrylic fibre, or their mixtures, of less than 50 percent. The outer layer of such fabrics shall also have a content of cellulosic, acetate or acrylic fibre, or their mixtures, of less than 50 percent.

#### 4.5 INFANT SLEEPBAGS

##### 4.5.1 Sleepbags designed to be opened at the bottom

Infant sleepbags that have sleeves or arm openings, with or without a front or back opening, and which are designed to be opened across or around the bottom by means of buttons, a zipper, a drawstring, elastic or any other reclosable fastening, shall comply with the requirements of this Section unless they comply with the requirements of Category 1 garments set out in Section 1.

##### 4.5.2 Sleepbags which are permanently closed at the bottom

Infant sleepbags that have sleeves or arm openings, with or without a front or back opening, but which are permanently closed across or around the bottom by their inherent design, or by a machined seam, are not required to comply with Clauses 4.3 or 4.4, but shall carry the label of a Category 4 garment unless they comply with the requirements for Category 1 garments set out in Section 1.

#### 4.6 FIRE HAZARD INFORMATION LABEL

The label to appear on garments which comply with this Section shall be in accordance with Section 5, and shall be as shown in Table 5.1.

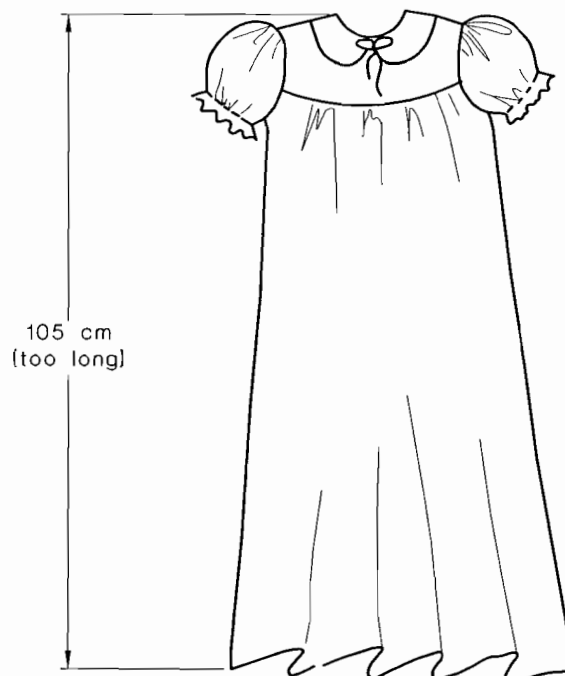

**LEGEND:**

Garment type:	Girl's nightie, Size 6
Fabric type:	85% cotton/15% polyester (more than 50% cellulosic)
Garment length:	105 cm (too long)
Fabric mass:	125 g/m <sup>2</sup> (within allowance)

FIGURE 4.1 EXAMPLE OF A GARMENT WHICH IS NOT ACCEPTABLE UNDER CLAUSE 4.3

**TABLE 4.1**  
**MAXIMUM GARMENT LENGTH FOR RESTRICTED**  
**FABRICS IN CATEGORY 4\* FOR GIRLS AND BOYS**

Size	Maximum length single- piece garment or jacket†	Maximum length pyjama trouser‡
	cm	cm
00	38	23
0	44	26
1	48	29
2	52	31
3	55	33
4	60	36
5	64	39
6	68	41
7	70	44
8	73	47
9	76	49
10	79	51
11	82	54
12	86	56
14	92	60

\* These requirements were derived from AS 1182, in order to provide for garments which do not extend below the knee.

† Measurement from the shoulder neck point (see Figure 2.1) to the bottom of the garment.

‡ Measured from the waist to the bottom of the garment. Includes an allowance for waistband.

## SECTION 5 MARKING

### 5.1 SCOPE OF SECTION

This Section sets out the requirements for labelling of children's nightwear.

### 5.2 INFORMATION TO BE SUPPLIED

Garments shall be clearly and permanently marked with the following information:

- (a) The name or trademark of the manufacturer or supplier.
- (b) The numerical garment size.
- (c) The fire hazard in accordance with one of the classifications given in Table 5.1.
- (d) Where a garment is made from fabrics which have been treated by chemical means to reduce the risk of burning, cleaning instructions suitable for preserving the treatment applied to the fabric.

### 5.3 LOCATION OF LABEL INCORPORATING THE FIRE HAZARD INFORMATION

The following shall apply:

- (a) The label shall be located inside the back neck of a top or one-piece garment. In pants, the label shall be located at the waist or waistband or at the top of the centre back seam. The labels shall be as close as possible to the top and centre of each piece as the design allows.
- (b) The fire hazard information (see Clause 5.5) and the garment size shall be clearly visible on the face side of the label and not obscured by any other label.
- (c) The label for Category 4 garments shall not contain any information other than the fire hazard information.  
NOTE: The label for Categories 1 to 3 garments may have other information on the label together with the fire hazard information.
- (d) If a garment is offered for retail sale in a package that obscures the label on the garment, the package shall also be prominently marked anywhere on the package with the information and warnings that are required to be put on the garment label as specified in Clause 5.5 (a)–(f).
- (e) Where there is more than one piece, each piece shall be labelled in accordance with the highest fire hazard category of any piece in the garment.

### 5.4 DURABILITY OF LABEL INCORPORATING THE FIRE HAZARD INFORMATION

The following shall apply:

- (a) Labels shall be placed on garments so that they are permanently fixed to withstand the cleaning treatment given for the garment to which they are attached, and to remain attached to the garment throughout its useful life.
- (b) When tested in accordance with Appendix J—
  - (i) the label and seam construction or attachment of each sample shall be intact;
  - (ii) the wording on each label shall be readable; and

- (iii) the numerical rating for colour change of the fire hazard information shall be not less than Grey Scale 4.

## 5.5 FIRE HAZARD INFORMATION AND SYMBOL

The fire hazard wording and symbol on labels shall comply with the following requirements:

- (a) The wording for each category shall be as shown in Table 5.1, Column 3.
- (b) Each statement on labels for Category 4 garments shall commence on a separate line. (See some examples of labels in Figure 5.1).
- (c) The wording shall be clearly legible in upper case, monoline, geometric lineale typeface of medium width characters not less than 2.5 mm high (see Note). The word 'warning' shall be in bold, upper case, typeface.

NOTES: Typeface descriptions for 'monoline', 'geometric', 'lineale' and 'medium width' are defined as follows:

- (i) Monoline—any typeface in which all strokes of the letters are apparently of equal thickness.
  - (ii) Geometric—lineale typefaces constructed on simple geometric shapes, such as circles or rectangles.
  - (iii) Lineale—typefaces without serifs (formerly called 'sans-serif').
  - (iv) Medium width—the width which the manufacturer (of the type) puts forward under the name of the family (i.e. the group of typefaces which are derived from one basic design) as the normal width from which variants in the family have been or may be derived.
- (d) The design of the symbol used on labels for Category 4 garments shall be as shown in Table 5.1, Column 3 and the triangle shall be not less than 17 mm in height and not less than 33 mm length at the base.
  - (e) The wording on labels for Category 1, 2 and 3 garments shall be black on a white label. The words may appear on more than one line.
  - (f) The wording and the symbol on labels for Category 4 garments shall be black on a red label.
  - (g) The red label colour shall be R13 Signal Red, as specified in AS 2700 or 537 Signal Red as specified in NZS 7702. When visually rated with the Grey Scale for assessing change in colour, complying with ISO 105 Part A02, the numerical rating of colour difference between the actual colour and the specified colour shall be not less than 4.

## 5.6 PAPER PATTERNS

Any paper pattern for children's nightwear within the scope of this Standard shall bear a warning paragraph on the outside of the envelope with the following wording:

### **FIRE WARNING:**

Regardless of the fabrics recommended on this package as suitable for this garment, for the safety of your children, do not make loose-fitting or nightdress styles from fabrics which burn readily. Avoid chenille, molleton and flannelette fabrics made from 100% cotton, and acrylic fabrics.

The typeface shall be not less than 2 mm high of medium width as follows:

- (a) The words '**FIRE WARNING**' should be in bold, upper case lettering.
- (b) Other words shall be in light face upper and lower case lettering.

**TABLE 5.1**  
**LABELLING OF CHILDREN'S NIGHTWEAR FOR FIRE HAZARD**

Classification	Description	Fire hazard information label
Category 1	Garments made from fabrics of the low fire hazard type which comply with Section 1.	LOW FIRE DANGER
Category 2	Garments made from fabric which does not comply with Section 1, but which are designed to reduce fire hazard and comply with Section 2.	
Category 3	All-in-one garments made predominantly from knitted fabrics in Sizes 00 to 2 which comply with Section 3.	
Category 4	Garments which do not comply with the requirements given in Sections 1 to 3, but which comply with Section 4.	<p><b>WARNING</b>  HIGH FIRE DANGER  KEEP AWAY FROM FIRE</p> 

NOTE: Label size and shape are optional (see Figure 5.1 for some examples).

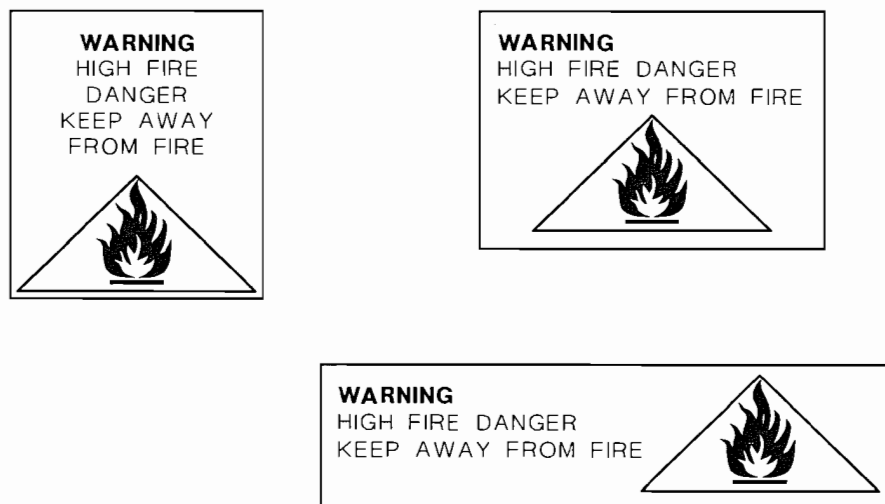
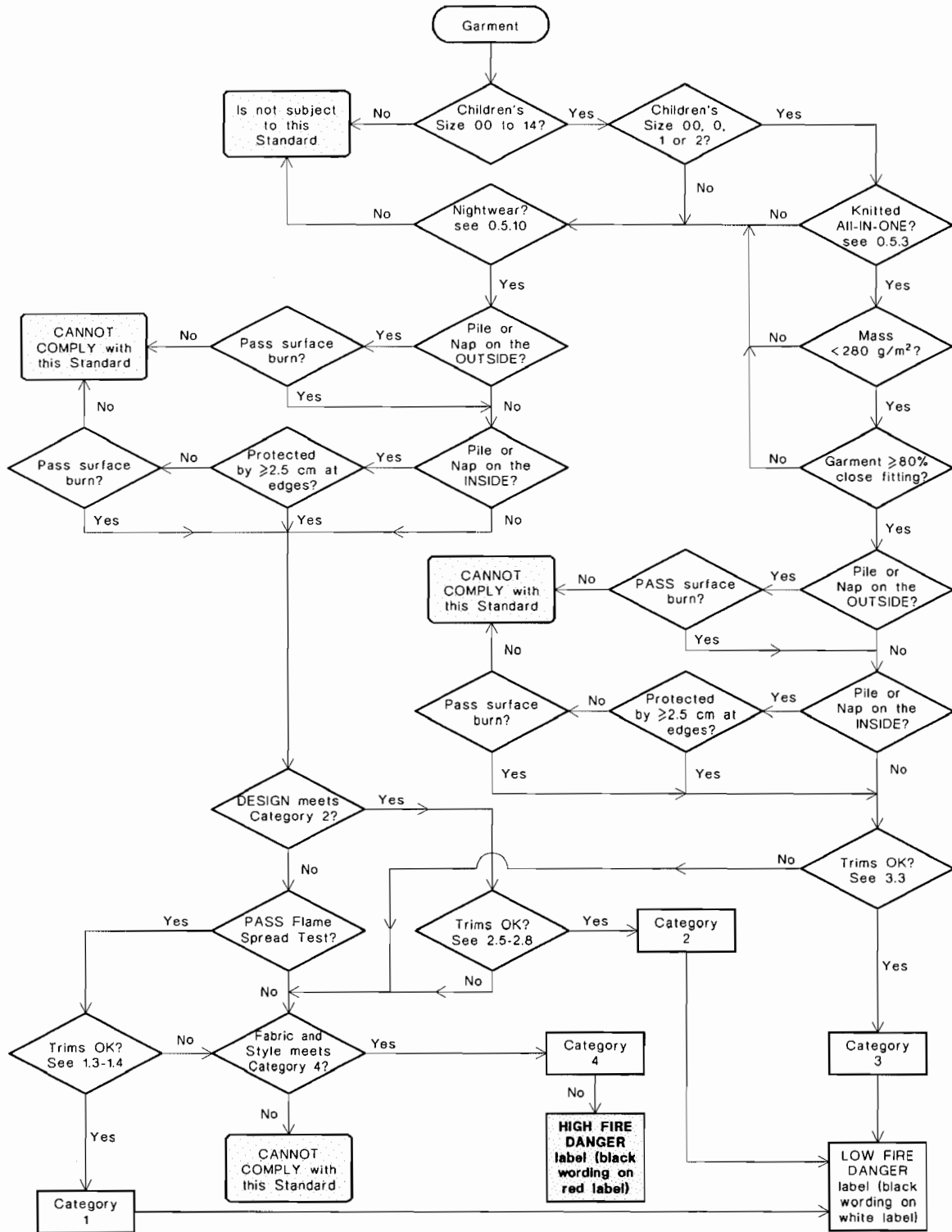

FIGURE 5.1 SOME EXAMPLES OF CATEGORY 4 LABELS

APPENDIX A

GUIDE TO THE PROCEDURE FOR DETERMINING THE CATEGORIES FOR CHILDREN'S NIGHTWEAR AND LIMITED DAYWEAR

(Informative)





APPENDIX B  
GENERAL INDICATION OF THE BURNING BEHAVIOUR OF  
DIFFERENT CLASSES OF FIBRES

(Informative)

### B1 SCOPE

This Appendix is intended to provide a general indication of the burning behaviour of different classes of fibres. It is intended to be for guidance purposes only.

**WARNING: THESE INDICATORS SHOULD NOT BE USED TO ASSESS WHETHER A FABRIC MADE OF A CERTAIN FIBRE WOULD OR WOULD NOT COMPLY WITH THE REQUIREMENTS OF THIS STANDARD. IN ORDER TO OBTAIN SUCH INFORMATION, TESTING SHOULD BE CARRIED OUT AS SPECIFIED IN THIS STANDARD.**

### B2 GENERAL

A general indication of the burning behaviour of different types of fibres is given in Table B1. The list of trade names in Table B1 is not intended to be all-inclusive but covers most fibres that are available.

**TABLE B1  
AN INDICATION OF BURNING BEHAVIOUR OF FIBRES**

Class of fibre	Generic name	Some trade names and common names	Notes
Natural cellulose	Cotton Linen	—	All burn readily unless given adequate flame-retardant treatments
Protein (animal)	Wool Silk Mohair Hair and fur	—	Usually difficult to ignite, burn slowly, and, in heavier weight cloths, tend to extinguish. Very lightweight cloths may burn strongly
Man-made*	Cupro Viscose Modal or polynosic	Evlan, Rayon, Cupresa, Vincel	Regenerated cellulose fibres burn readily unless given an adequate flame-retardant treatment
	Cellulosic acetate (including triacetate)	Arnel, Dixel, Tricel, Filcel, Textella	Burn before melting. They ignite and burn readily, and generally drip molten polymer
	Flame-retardant regenerated cellulose fibres	—	The fibre is made with flame-retardant compounds incorporated in the resin. It burns slowly, and is more difficult to ignite than other regenerated cellulose fibres

*(continued)*

TABLE B1 (continued)

Class of fibre	Generic name	Some trade names and common names	Notes
Man-made (continued)	Acrylic	Acrilan, Beslon, Cashmilon, Courtelle, Creslan, Crylor, Exlan, Dolan, Dralon, Orlon, Zefran, Vonnell, Filcryl, Nomelle	Generally burn before melting, although some ignite only with difficulty. Once ignited, acrylic fibres burn strongly and may drip molten polymer
	Polyamide	Antron, Bri-Nylon, Caprolan, Celon, Enklon, Nylon 6, Nylon 11 (Rilsan), Nylon 66, Nylon 610, Perlon, Amilan, Antron, Cantrece, Delfion, Dorix, Fluflon, Promilan	The fibres melt when heat is applied and generally drip away from the flame. When blended with some fibres (e.g. cotton, rayon or wool) they are unable to drip away from the flame and will burn, often quite fiercely. Polyamide fabric may also burn when sewn into a garment with cotton thread; the threads may act as a support to prevent the burning fibre from dripping away
	Chloro-fibres (polyvinyl chloride, polyvinylidene chloride and copolymers)	Clevyl, Geon, Movil, PeCe, Tevion, Thermovyl, Tygan Valren, Vinylon, Rhovyl	These fibre generally do not burn under normal conditions. On application of a flame they shrink away. If ignition does occur, burning ceases on removal of the flame
	Modacrylic	Kanekalon, Teklan, Verel, Vonnell	Fibres are difficult to ignite. Flammability properties very similar to those of chlorofibres
	Polyester	Dacron, Diolen, Fortrel, Kodel, Tergal, Terlenka, Trevira, Vycron, Crimplene	Very similar flammability characteristics to polyamide fibres
	Flame-retardant polyester	—	The fibre is made with flame-retardant compounds incorporated in the resin. They have reduced burning characteristics in blends
	Polyethylene and polypropylene	Courlene, Drylene, Herculon, Marvess, Meraklon, Nymbplex, Polycrest, Pylene, Reevon, Spunston, Ulstron	These fibres melt when ignited and drip molten drops while continuing to burn
	Vinylal (Polyvinyl alcohol)	Mewlon, Vinylon, Kuralon	Similar flammability characteristics to polyethylene and polypropylene fibres but burn somewhat less rapidly
	Other fibres of various types	Durette, Kynol, Nomex, PBI, Kevlar, Cordelan	These fibres do not burn under normal conditions.

\* These fibres exhibit a variety of flammability properties. Some burn, some melt and drip away, yet others burn with difficulty.

APPENDIX C  
INDICATIONS OF NIGHTWEAR FOR CHILDREN'S GARMENTS  
(Informative)

### C1 SCOPE

This Appendix sets out some indicators which will assist in determining whether a garment is defined as a nightwear garment under this Standard.

### C2 STYLING FACTORS

#### C2.1 Indications of nightwear

Some styling factors which are likely to indicate nightwear are—

- (a) night time/sleepy themes, for example, moons and stars; and
- (b) garments of a type suitable for nightwear as defined in this Standard (see Clause 0.5.10).

#### C2.2 Indications that the garment is not suitable for nightwear

Some styling factors which are likely to indicate that the garment is not suitable for nightwear are—

- (a) extensive bows/lace/embroidery or other decorative work which would disturb a child during sleep;
- (b) hoods;
- (c) heavy fabrics such as denim/corduroy;
- (d) plastic-soled feet in garments;
- (e) ribbing on the inside of a garment which would otherwise impress on a child's skin during sleep;
- (f) polo shirts (knitted sports shirts);
- (g) heavy or decorative studs or fasteners; and
- (h) overalls and overall styles (woven) between sizes 00–2.

### C3 GARMENTS

Garments likely to be classified as daywear and not included in this Standard are—

- (a) dresses;
- (b) skirts and tops;
- (c) shorts and tops sets;
- (d) knitted, form-fitting boxer shorts;
- (e) track tops and pants;
- (f) bodysuits above Size 2;
- (g) cardigans/jackets;
- (h) leggings; and
- (i) parkas.

**C4 GARMENTS EXCLUDED FROM THIS STANDARD**

Excluded from this Standard are—

- (a) headwear;
- (b) footwear;
- (c) underwear (except as it applies under Clause 0.5.3);
- (d) handwear; and
- (e) swimwear.

NOTE: Garments excluded from this Standard that are part of a set do not require fire hazard labelling.

**C5 IRRELEVANT FACTORS**

Factors which are generally irrelevant with respect to the determination of nightwear are—

- (a) with the exception of Paragraph C2.2(c), the type of fabric used;
- (b) style coordinated accessories (e.g. detachable bibs, hats, headbands, gloves and booties);
- (c) the colour of the garment e.g. pastels are not indicative of nightwear; and
- (d) 'designed for daywear' labels.

**APPENDIX D**  
**WASH PROCEDURE**  
(Normative)

**D1 SCOPE**

This Appendix sets out the procedure for the washing of children's nightwear for determining the retention of burning behaviour properties of textile fabrics.

**D2 TEST SAMPLE**

The sample shall be selected and prepared as follows:

- (a) The selected sample shall be representative of the material under test.
- (b) The sample shall be large enough to provide test specimens required for carrying out the tests set out in ISO 6941 and ISO 10047.
- (c) Samples which have raw edges shall be hemmed to prevent fraying.

**D3 PROCEDURE**

The sample(s) shall be washed twice in accordance with Table D1. After the second wash, the sample(s) shall be tumble dried at a temperature which will not damage the fibre.

**TABLE D1**  
**WASHING CONDITIONS**

Composition of fabric	Washing procedure in accordance with AS 2001.5.4
Cotton, linen	2A or 2B
Polyamides, polyester, regenerated cellulosic fibres	4A or 4B
Acrylics, chlorofibres modacrylics, acetates, wool, silk	7A or 7B
All other fibres and blends	Washing conditions and treatment shall be selected from the above according to the type of fibre or the fibre predominating in the blend

APPENDIX E  
TABLES RELATED TO TRIMS REQUIREMENTS  
(Normative)

**TABLE E1**  
**TOTAL AREA OF APPLIQUES, MOTIFS AND OVERLAYS,**  
**AND ALSO INSERTS, FOR CATEGORY 1 AND**  
**CATEGORY 2 GARMENTS**

Garment size	Total area, cm <sup>2</sup>
00-3	90
4-7	135
8-14	180

**TABLE E2**  
**WAISTLINE AND ELBOW POSITIONS**

Garment size	Waistline position—Maximum distance from cervical to waist (at back)	Elbow position—Maximum distance from cervical point (see Figure E1)
	cm	cm
00	17	20
0	19	21.5
1	21	25
2	23	27.5
3	25	29
4	26	31.5
5	27	33
6	28	35.5
7	29	36.75
8	29	38
9	30	39.5
10	31	41
11	32	42.5
12	34	45
14	39	47

NOTES:

- 1 The waistline position distances are calculated from AS 1182.
- 2 The elbow position distances are calculated from Snyder, R.G., Schneider, L.W., Owings, C.L., Reynolds, H.M., Golomb, D.H. and Schork, M.A. *Anthropometry of infants, children and youths to age 18 for product safety design*. Final report prepared for Consumer Product Safety Commission, by Highway Safety Research Institute, The University of Michigan. Warrendale, PA: Society of Automotive Engineers, 1977.

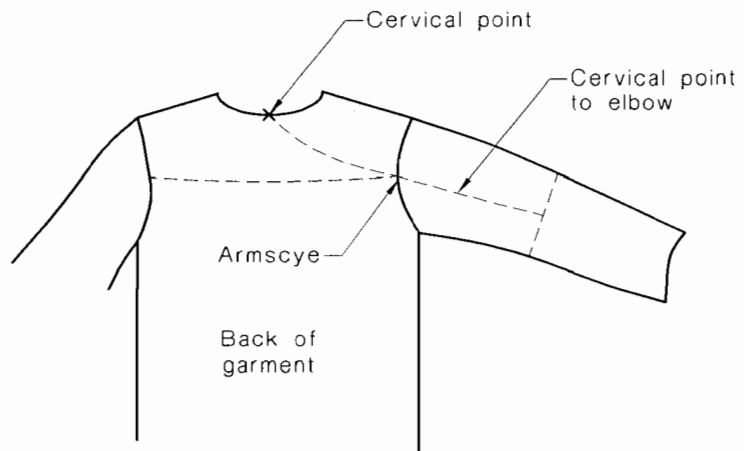

FIGURE E1 LOCATION OF MEASUREMENT POINTS FOR ELBOW POSITION

## APPENDIX F

METHOD OF TEST FOR CATEGORY 1 AND CATEGORY 2 GARMENTS  
WHICH HAVE A TOTAL AREA OF APPLIQUES, MOTIFS AND  
OVERLAYS GREATER THAN THAT PERMITTED IN  
APPENDIX E, TABLE E1

(Normative)

**F1 SCOPE**

This Appendix specifies a method for testing garments for the comparison of flame spread time performance of the fabric with and without trim.

**F2 METHOD**

The test shall be in accordance with ISO 6941 with a 10 s surface ignition time, except for the following:

- (a) Specimens shall be tested in the length direction only.
- (b) Six specimens shall be taken, three of these consisting of the base fabric only and three consisting of the base fabric and trim.
- (c) Specimens of base fabric and trim combination shall be tested in accordance with Clause 1.2(c).

**F3 TEST REPORT**

The following shall also be reported:

- (a) The number of specimens tested—
  - (i) without trim; and
  - (ii) with trim.
- (b) The mean time taken for the flame to travel from the first to the third marker threads—
  - (i) without trim; and
  - (ii) with trim.
- (c) Whether the flame failed to reach the first marker thread for any or all of the specimens tested—
  - (i) without trim; and
  - (ii) with trim.
- (d) Whether the flame failed to reach the third marker thread for any or all of the specimens tested—
  - (i) without trim; and
  - (ii) with trim.
- (e) A reference to this method, i.e. AS/NZS 1249, Appendix F.



## APPENDIX G

SOME EXAMPLES OF CALCULATING ALLOWABLE AMOUNT  
OF TRIMS—CATEGORY 1 GARMENTS

(Informative)

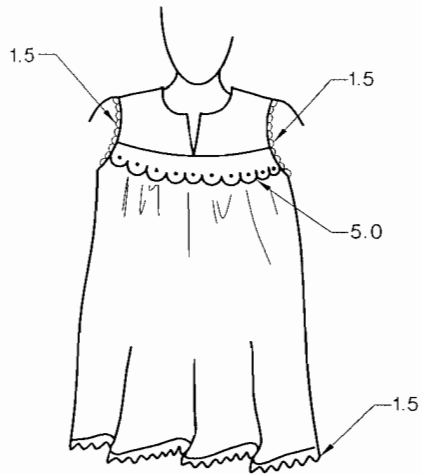

Sum of free edge of the trims (excluding edge trims)  
1 trim = 5 cm which is the maximum allowable

(a)



Total area of three motifs is within the area in Appendix E, Table E1

(b)

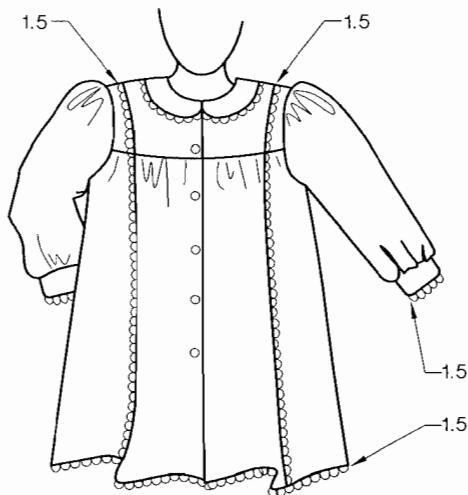

Sum of free edges of trims (excluding edge trims)  $1.5 \text{ cm} + 1.5 \text{ cm} = 3.0 \text{ cm}$  which is within the maximum allowable

(c)

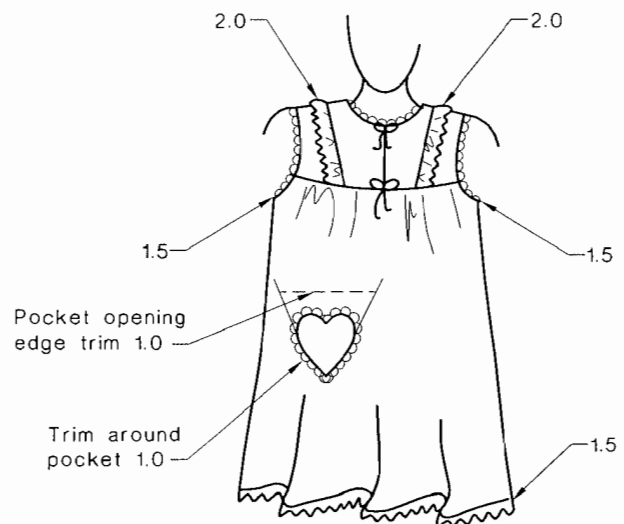

Sum of free edges of trims (excluding edge trims)  $2.0 \text{ cm} + 2.0 \text{ cm} + 1.0 \text{ cm} = 5.0 \text{ cm}$  which is the maximum allowable

(d)

## NOTES:

- 1 There are no design requirements for the use of trims where both the garment and the trim comply with Clause 1.2.
- 2 Dressing gowns designed with a belt are preferred, as a belt worn around the waist can halt the progression of fire or flame.

DIMENSIONS IN CENTIMETRES

COPYRIGHT

APPENDIX H

SOME EXAMPLES OF TRIMS WHICH EXCEED ALLOWABLE AMOUNT AND WHICH THEREFORE ARE NOT ACCEPTABLE—  
CATEGORY 1 GARMENTS

(Informative)

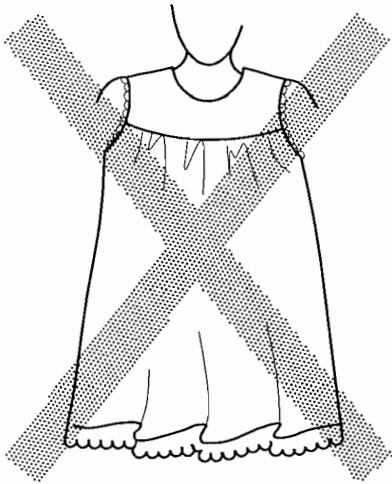

Edge trim has a free edge which is wider than 1.5 cm.  
**Not acceptable**

(a)

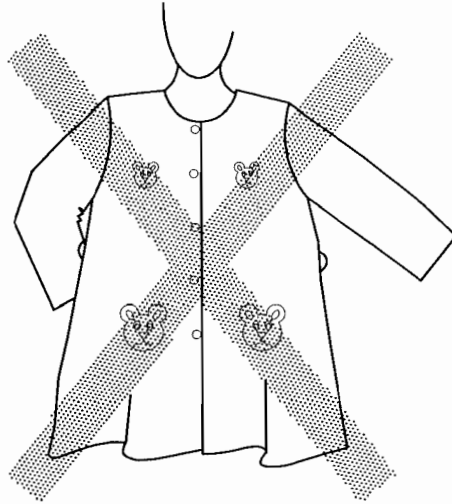

Total area of motifs or appliques exceeds the limit in Appendix E, Table E1.  
**Not acceptable**

(b)

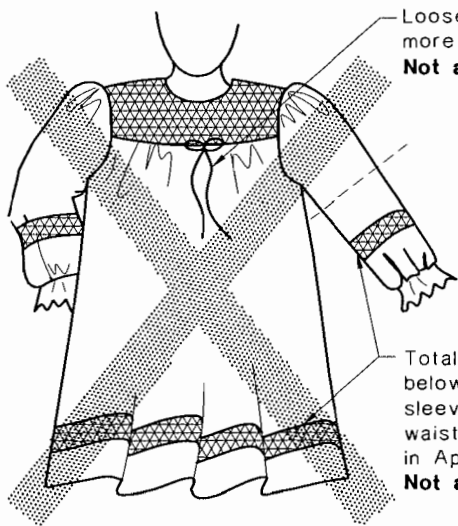

Loose portion extending more than 10 cm.  
**Not acceptable**

Total area of inserts below the elbow on the sleeve and below the waistline exceeds the limit in Appendix E, Table E1.  
**Not acceptable**

(c)

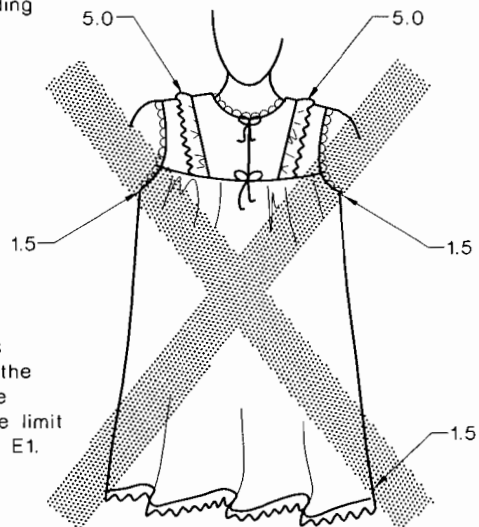

Sum of free edges of trims (excluding edge trims) 5.0 cm + 5.0 cm = 10.0 cm.  
**Not acceptable**

(d)

NOTE: There are no design requirements for the use of trims where both the garment and the trim comply with Clause 1.2.

DIMENSIONS IN CENTIMETRES

## APPENDIX 1

EXAMPLES OF STYLES OF GARMENTS WHICH COMPLY WITH THE  
DESIGN REQUIREMENTS FOR CATEGORY 2 GARMENTS

(Informative)

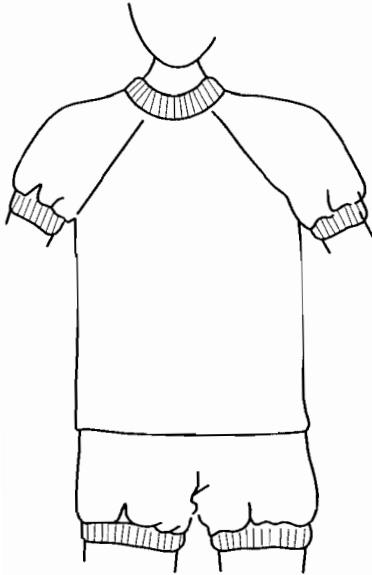

(a) Short pyjama



(b) Short pyjama



(c) Short pyjama

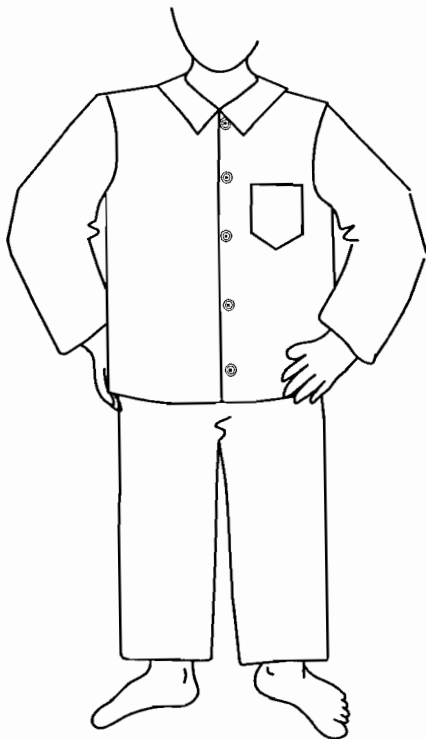

(d) Standard two-piece pyjama

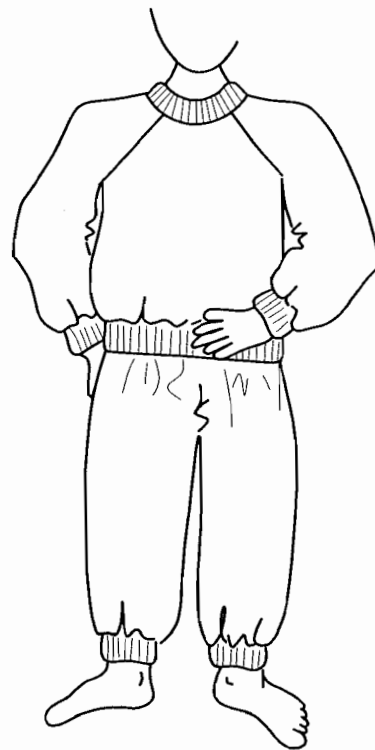

(e) 'Ski' pyjama with basques

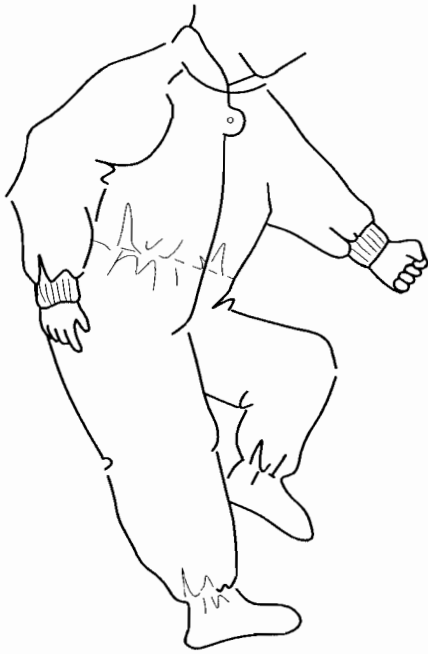

(f) Coverall style\*

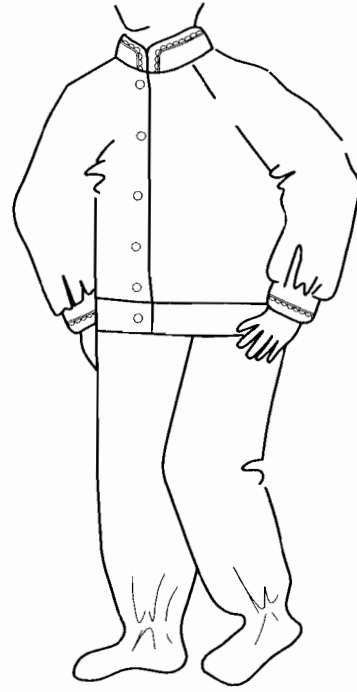

(g) Two-piece tracksuit style pyjama with feet

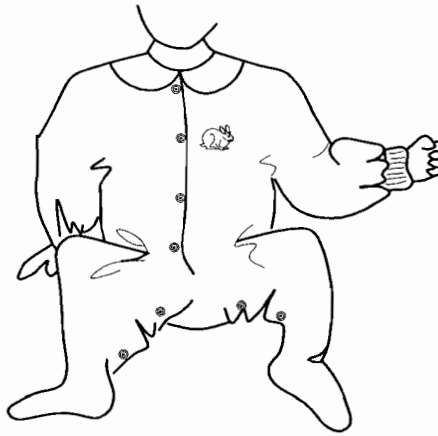

(h) All-in-one sleep suit with stud openings\*

---

\* If predominantly knitted and Sizes 00 to 2, these should be considered under Category 3.

## APPENDIX J

METHOD FOR DETERMINING DURABILITY AND ATTACHMENT OF LABEL  
INCORPORATING FIRE HAZARD INFORMATION

(Normative)

**J1 SCOPE**

This Appendix sets out a method for testing labels incorporating fire hazard information for their durability and their attachment to children's nightwear.

**J2 TEST SAMPLES**

Two labels shall be tested.

Where the labels are attached to or sewn into a garment, test specimens shall be cut from the garment so that there is a portion of the garment fabric at the point of attachment about 1 cm on each side of the label and about 2.5 cm of the fabric beyond the label (see Figure J1(a)).

Test the labels in their position as received, leaving 1 cm either side of the outer label, 1 cm above the label attachment and 2.5 cm of the base fabric below the label attachment.

Where labels which are not attached to garments are being tested, they shall be attached to a piece of fabric or sewn into a seam in the manner in which they will be used. The two labels may be attached to the one piece of fabric spaced 5 cm apart, ensuring there is 1 cm of fabric beyond the outside edge of the label 1 cm above the label attachment and 2.5 cm of the base fabric below the label attachment (see Figure J1(b)).

The cut edges of the fabric and seam shall be sealed with a waterproof adhesive, or be overlapped, to prevent fraying, if required.

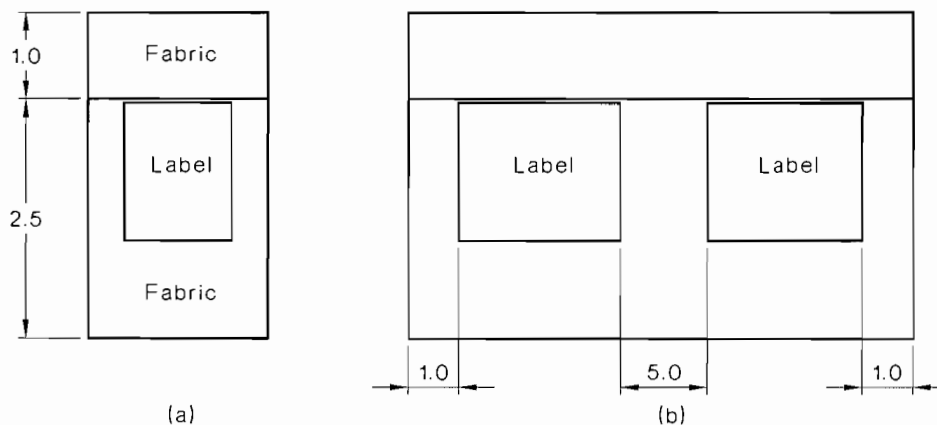

Raw edges sealed or overlapped

DIMENSIONS IN CENTIMETRES

FIGURE J1 TEST LABEL

**J3 TEST METHOD**

The apparatus, procedure and report shall be in accordance with AS 2001.4.15, Test J1.

NOTES

NOTES

NOTES



### **Standards Australia**

Standards Australia is an independent company, limited by guarantee, which prepares and publishes most of the voluntary technical and commercial standards used in Australia. These standards are developed through an open process of consultation and consensus, in which all interested parties are invited to participate. Through a Memorandum of Understanding with the Commonwealth government, Standards Australia is recognized as Australia's peak national standards body.

### **Standards New Zealand**

The first national Standards organization was created in New Zealand in 1932. The Standards Council of New Zealand is the national authority responsible for the production of Standards. Standards New Zealand is the trading arm of the Standards Council established under the Standards Act 1988.

### **Australian/New Zealand Standards**

Under an Active Co-operation Agreement between Standards Australia and Standards New Zealand, Australian/New Zealand Standards are prepared by committees of experts from industry, governments, consumers and other sectors. The requirements or recommendations contained in published Standards are a consensus of the views of representative interests and also take account of comments received from other sources. They reflect the latest scientific and industry experience. Australian/New Zealand Standards are kept under continuous review after publication and are updated regularly to take account of changing technology.

### **International Involvement**

Standards Australia and Standards New Zealand are responsible for ensuring that the Australian and New Zealand viewpoints are considered in the formulation of international Standards and that the latest international experience is incorporated in national and Joint Standards. This role is vital in assisting local industry to compete in international markets. Both organizations are the national members of ISO (the International Organization for Standardization) and IEC (the International Electrotechnical Commission).

### **Visit our Web sites**

[www.standards.com.au](http://www.standards.com.au)

[www.standards.co.nz](http://www.standards.co.nz)

---

**AS/NZS 1249:2003**

**CHILDREN'S NIGHTWEAR AND LIMITED DAYWEAR HAVING  
REDUCED FIRE HAZARD**

**AMENDMENT A (NEW ZEALAND-ONLY)**

May 2008

---

**REVISED TEXT**

---

**EXPLANATORY NOTE**

This New Zealand-only amendment updates the labelling of Category 2 and 3 garments, following two children being badly burned when wearing Category 2 garments in 2007.

Investigation of these two incidents and research into consumer's understanding of children's nightwear labelling, identified a misperception about the meaning of Low Fire Danger labelling for Category 2 and 3 garments.

The updated labelling is to inform consumers that the garments are not heat or flame resistant and should be snug-fitting to reduce risk.

---

**APPROVAL**

New Zealand-only amendment A was approved on 20 May 2008 by the Minister of Consumer Affairs and on 26 May 2008 by the Standards Council to be an amendment to AS/NZS 1249:2003.

(Amendment A, May 2008)

---

Delete Table 0.1 (page 10) and substitute:

**TABLE 0.1**  
**CATEGORIES OF CHILDREN'S NIGHTWEAR**

Category	Description	Fire hazard information label
1	Garments made from fabric of the low fire hazard type and which comply with Section 1	<b>LOW FIRE DANGER</b>
2	Garments made from fabric which does not comply with Section 1 but which are designed to reduce fire hazard and which comply with Section 2	<b>CAUTION</b> NOT HEAT OR FLAME RESISTANT WEAR SNUG-FITTING TO REDUCE RISK
3	All-in-one garments made predominantly from knitted fabrics, in Sizes 00 to 2, which comply with Section 3	
4	Garments which do not comply with Sections 1 to 3, but which comply with Section 4	<b>WARNING</b> HIGH FIRE DANGER KEEP AWAY FROM FIRE 

NOTE: See Section 5 and Table 5.1 for labelling requirements.

(Amendment. A, May 2008)

**5.3 LOCATION OF LABEL INCORPORATING THE FIRE HAZARD INFORMATION** (page 25)

**5.3 Delete item (c) and substitute:**

- (c) The label for Category 2, 3 and 4 garments shall not contain any information other than the fire hazard information.

NOTE: The label for Category 1 garments may have other information on the label together with the fire hazard information.

(Amendment. A, May 2008)

**5.5 FIRE HAZARD INFORMATION AND SYMBOL** (page 26)

**5.5 (c) Delete** the second sentence and **substitute:**

The words 'warning' and 'caution' shall be in bold, upper case, typeface.

**5.5 (e) Delete** '2 and 3'.

**5.5 Add** two new subclauses:

- (h) The wording on labels for Category 2 and 3 garments shall be black on an orange label. The words may appear on more than one line.
- (i) The orange label colour shall be marigold, as specified in AS 2700 or light orange as specified in NZS 7702. When visually rated with the 'Grey scale for assessing change in colour', complying with ISO 105 Part A02, the numerical rating of colour difference between the actual colour and the specified colour shall be not less than 4.

(Amendment A, May 2008)

**Delete** Table 5.1 (page 27) and **substitute:**

**TABLE 5.1**  
**CATEGORIES OF CHILDREN'S NIGHTWEAR**

Category	Description	Fire hazard information label
1	Garments made from fabric of the low fire hazard type and which comply with Section 1	<b>LOW FIRE DANGER</b>
2	Garments made from fabric which does not comply with Section 1 but which are designed to reduce fire hazard and which comply with Section 2	<b>CAUTION</b> NOT HEAT OR FLAME RESISTANT WEAR SNUG-FITTING TO REDUCE RISK
3	All-in-one garments made predominantly from knitted fabrics, in Sizes 00 to 2, which comply with Section 3	<b>WARNING</b> HIGH FIRE DANGER KEEP AWAY FROM FIRE
4	Garments which do not comply with Sections 1 to 3, but which comply with Section 4	<b>WARNING</b> HIGH FIRE DANGER KEEP AWAY FROM FIRE 

NOTE: Label size and shape are optional (see Figure 5.1 for some examples).

(Amendment A, May 2008)

Appendix A (page 28) – Delete the flow chart and substitute:

A5/NZS 1249:2003

28

APPENDIX A

GUIDE TO THE PROCEDURE FOR DETERMINING THE CATEGORIES FOR CHILDREN'S NIGHTWEAR AND LIMITED DAYWEAR

(Informative)

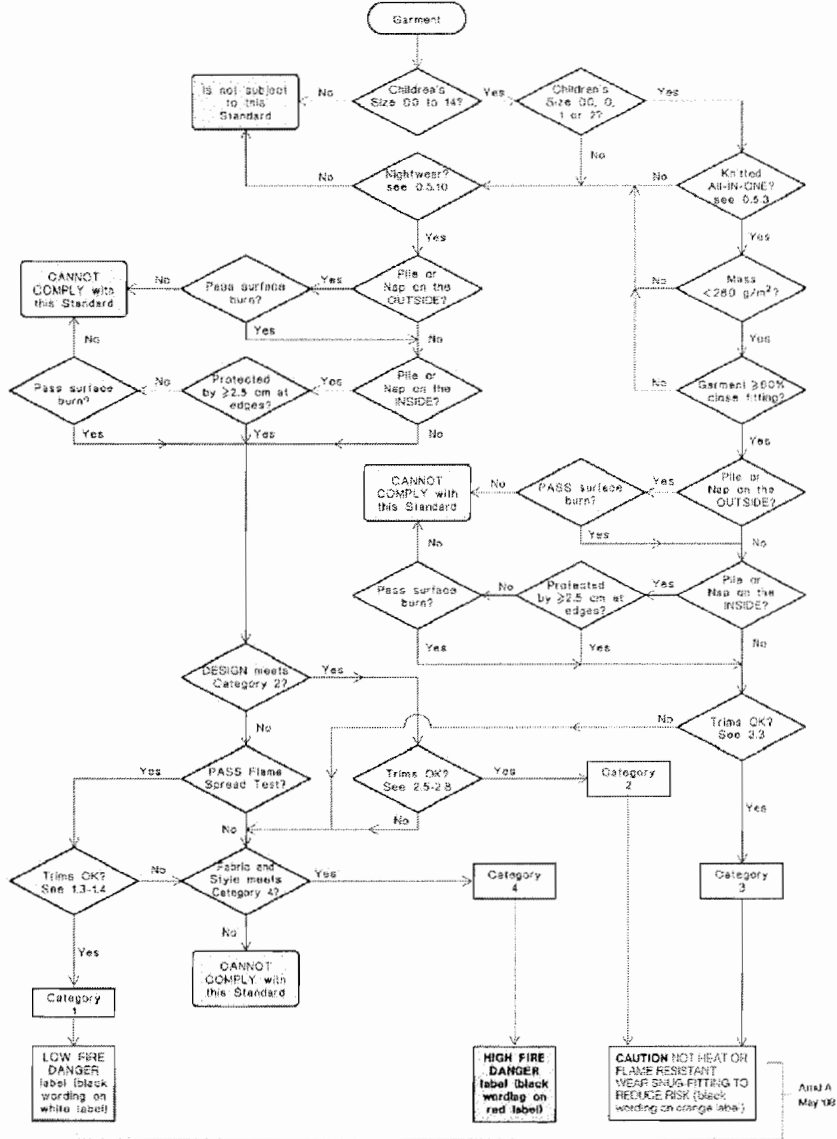

COPYRIGHT

(Amendment A, May 2008)

---

## **AS/NZS 1249:2003**

# **CHILDREN'S NIGHTWEAR AND LIMITED DAYWEAR HAVING REDUCED FIRE HAZARD**

### **AMENDMENT A (NEW ZEALAND-ONLY)**

May 2008

---

### **REVISED TEXT**

---

#### **EXPLANATORY NOTE**

This New Zealand-only amendment updates the labelling of Category 2 and 3 garments, following two children being badly burned when wearing Category 2 garments in 2007.

Investigation of these two incidents and research into consumer's understanding of children's nightwear labelling, identified a misperception about the meaning of Low Fire Danger labelling for Category 2 and 3 garments.

The updated labelling is to inform consumers that the garments are not heat or flame resistant and should be snug-fitting to reduce risk.

---

#### **APPROVAL**

New Zealand-only amendment A was approved on 20 May 2008 by the Minister of Consumer Affairs and on 26 May 2008 by the Standards Council to be an amendment to AS/NZS 1249:2003.

(Amendment A, May 2008)

---

Delete Table 0.1 (page 10) and substitute:

**TABLE 0.1**  
**CATEGORIES OF CHILDREN'S NIGHTWEAR**

Category	Description	Fire hazard information label
1	Garments made from fabric of the low fire hazard type and which comply with Section 1	<b>LOW FIRE DANGER</b>
2	Garments made from fabric which does not comply with Section 1 but which are designed to reduce fire hazard and which comply with Section 2	<b>CAUTION</b> NOT HEAT OR FLAME RESISTANT WEAR SNUG-FITTING TO REDUCE RISK
3	All-in-one garments made predominantly from knitted fabrics, in Sizes 00 to 2, which comply with Section 3	
4	Garments which do not comply with Sections 1 to 3, but which comply with Section 4	<b>WARNING</b> HIGH FIRE DANGER KEEP AWAY FROM FIRE 

NOTE: See Section 5 and Table 5.1 for labelling requirements.

(Amendment. A, May 2008)

**5.3 LOCATION OF LABEL INCORPORATING THE FIRE HAZARD INFORMATION** (page 25)

**5.3 Delete** item (c) and **substitute:**

- (c) The label for Category 2, 3 and 4 garments shall not contain any information other than the fire hazard information.

NOTE: The label for Category 1 garments may have other information on the label together with the fire hazard information.

(Amendment. A, May 2008)

## Single User PDF Download Terms & Conditions

You have downloaded material which is subject to strict conditions of use. Copyright in this material is owned by Standards New Zealand. Please read these terms and conditions carefully, as in addition to the usual range of civil remedies available to Standards New Zealand for infringement of copyright, under New Zealand law every person who infringes copyright may be liable to a fine not exceeding \$50,000 or to imprisonment for a term not to exceed three months.

You have purchased a single-user licence to store this non-revisable Adobe Acrobat PDF file on your personal computer. You may print out and retain ONE printed copy only.

Standards New Zealand retains title and ownership of the copyright in this PDF file and the corresponding permitted printed copy at all times.

Under this license use of both the PDF file and the single permitted printed copy of this PDF file you may make are restricted to you. Under no circumstances are you permitted to sell, transfer or copy this PDF file, the one permitted printed copy of this PDF file, or any part of either of them.

You undertake that you will not modify, adapt, translate, reverse engineer, decompile, disassemble or create derivative works based on any of the downloaded PDF file, nor will you merge it with any other software or document, even for internal use within your organization.

Under no circumstances may this PDF file be placed on a network of any sort without the express permission of Standards New Zealand.

You are solely responsible for the selection of this PDF file and any advice or recommendation given by Standards New Zealand or its employees or agents about any aspect of this PDF file is intended for guidance only and is followed or acted upon entirely at your own risk.

Standards New Zealand is not aware of any inherent risk of viruses in this PDF file at the time that it is downloaded. Standards New Zealand has exercised due diligence to ensure, so far as practicable, that this file does not contain such viruses.

No warranty of any form is given by Standards New Zealand or by any party associated with Standards New Zealand with regard to this PDF file, and you accept and acknowledge that Standards New Zealand will not be liable in any way to you or any to other person in respect of any loss or damage, however caused which may be suffered or incurred or which may arise directly or indirectly through any use of this PDF file.

Regardless of where you were when you downloaded this PDF file you accept and acknowledge that to the fullest extent possible you submit to New Zealand law with regard to this licence and to your use of this PDF file.



## NOTES

\*On 04/12/2012 08:20 AM Public.Resource.Org purchased a single use licence to store this document on a single computer.  
Public.Resource.Org may print and retain one copy only.

Copyright Standards New Zealand \*

**5.5 FIRE HAZARD INFORMATION AND SYMBOL** (page 26)

**5.5 (c) Delete** the second sentence and **substitute**:

The words 'warning' and 'caution' shall be in bold, upper case, typeface.

**5.5 (e) Delete** '2 and 3'.

**5.5 Add** two new subclauses:

- (h) The wording on labels for Category 2 and 3 garments shall be black on an orange label. The words may appear on more than one line.
- (i) The orange label colour shall be marigold, as specified in AS 2700 or light orange as specified in NZS 7702. When visually rated with the 'Grey scale for assessing change in colour', complying with ISO 105 Part A02, the numerical rating of colour difference between the actual colour and the specified colour shall be not less than 4.

(Amendment A, May 2008)

**Delete** Table 5.1 (page 27) and **substitute**:

**TABLE 5.1**  
**CATEGORIES OF CHILDREN'S NIGHTWEAR**

Category	Description	Fire hazard information label
1	Garments made from fabric of the low fire hazard type and which comply with Section 1	<b>LOW FIRE DANGER</b>
2	Garments made from fabric which does not comply with Section 1 but which are designed to reduce fire hazard and which comply with Section 2	<b>CAUTION</b> NOT HEAT OR FLAME RESISTANT WEAR SNUG-FITTING TO REDUCE RISK
3	All-in-one garments made predominantly from knitted fabrics, in Sizes 00 to 2, which comply with Section 3	
4	Garments which do not comply with Sections 1 to 3, but which comply with Section 4	<b>WARNING</b> HIGH FIRE DANGER KEEP AWAY FROM FIRE 

NOTE: Label size and shape are optional (see Figure 5.1 for some examples).

(Amendment A, May 2008)

Appendix A (page 28) – Delete the flow chart and substitute:

A5/NZS 1249:2003

28

APPENDIX A  
GUIDE TO THE PROCEDURE FOR DETERMINING THE CATEGORIES  
FOR CHILDREN'S NIGHTWEAR AND LIMITED DAYWEAR

(Informative)

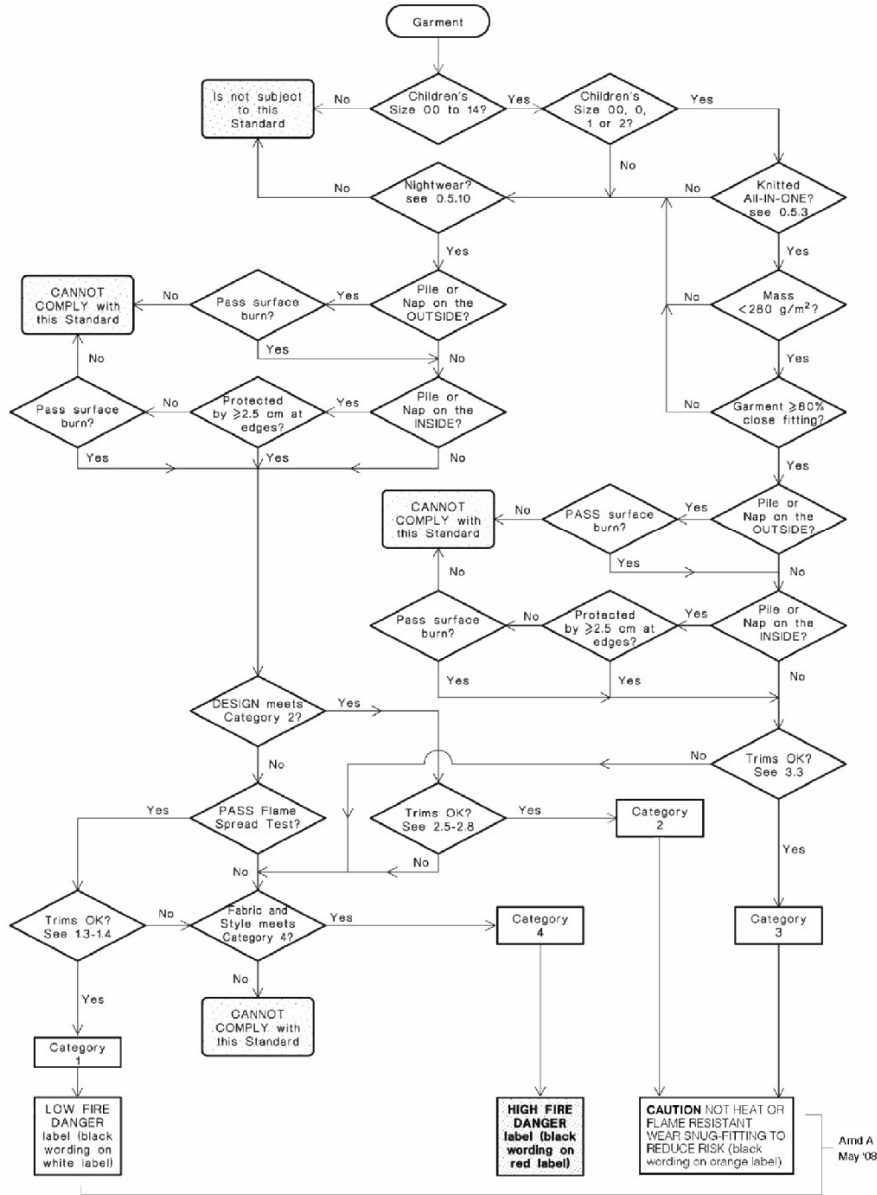

Amd A May 08

COPYRIGHT

(Amendment A, May 2008)

---

**© 2008 STANDARDS COUNCIL  
STANDARDS NEW ZEALAND  
PRIVATE BAG 2439  
WELLINGTON 6140**

---

© 2008 STANDARDS COUNCIL  
STANDARDS NEW ZEALAND  
PRIVATE BAG 2439  
WELLINGTON 6140





## **Standards Australia**

Standards Australia is an independent company, limited by guarantee, which prepares and publishes most of the voluntary technical and commercial standards used in Australia. These standards are developed through an open process of consultation and consensus, in which all interested parties are invited to participate. Through a Memorandum of Understanding with the Commonwealth government, Standards Australia is recognized as Australia's peak national standards body.

## **Standards New Zealand**

The first national Standards organization was created in New Zealand in 1932. The Standards Council of New Zealand is the national authority responsible for the production of Standards. Standards New Zealand is the trading arm of the Standards Council established under the Standards Act 1988.

## **Australian/New Zealand Standards**

Under a Memorandum of Understanding between Standards Australia and Standards New Zealand, Australian/New Zealand Standards are prepared by committees of experts from industry, governments, consumers and other sectors. The requirements or recommendations contained in published Standards are a consensus of the views of representative interests and also take account of comments received from other sources. They reflect the latest scientific and industry experience. Australian/New Zealand Standards are kept under continuous review after publication and are updated regularly to take account of changing technology.

## **International Involvement**

Standards Australia and Standards New Zealand are responsible for ensuring that the Australian and New Zealand viewpoints are considered in the formulation of international Standards and that the latest international experience is incorporated in national and Joint Standards. This role is vital in assisting local industry to compete in international markets. Both organizations are the national members of ISO (the International Organization for Standardization) and IEC (the International Electrotechnical Commission).

## **Visit our Web sites**

[www.standards.org.au](http://www.standards.org.au)

[www.standards.co.nz](http://www.standards.co.nz)





**STANDARDS**

**NEW ZEALAND**

PAEREWA AOTEAROA

